

IS24C08A/16A

2-WIRE (I²C)

8K/16K-bit

AUTOMOTIVE

SERIAL EEPROM



TABLE OF CONTENTS

Features3

Description3

Functional Block Diagram4

Pin Configuration & Description5

Device Operations6

Absolute Maximum Ratings14

DC Characteristics14

AC Characteristics15

Ordering Information16

Packaging Information17



IS24C08A IS24C16A

8K-bit/16K-bit 2-WIRE SERIAL CMOS EEPROM

ADVANCED INFORMATION
SEPTEMBER 2009

FEATURES

- Two-Wire Serial Interface, I²C™ Compatible
 - Bi-directional data transfer protocol
- Wide Voltage Operation
 - V_{cc} = 2.7V to 3.6V
- Frequency: 400 KHz (2.7V)
- Low Power
 - Standby Current: 6 μA (3.6V)
 - Read Current less than 2 mA (3.6V)
 - Write Current less than 3 mA (3.6V)
- Hardware Data Protection
 - Write Protect Pin
- Sequential Read Feature
- Filtered Inputs for Noise Suppression
- Self time write cycle with auto clear
 - 5 ms max @ 2.7V
- Memory Organization
 - IS24C08A: 1024x8 (four blocks of 256 bytes)
 - IS24C16A: 2048x8 (eight blocks of 256 bytes)
- 16 Byte Page Write Buffer
- High Reliability
 - Endurance: 1,000,000 Cycles
 - Data Retention: 100 Years
- Automotive temperature grade
- Packages: SOIC/SOP and TSSOP

DESCRIPTION

The IS24C08A and IS24C16A are EEPROM devices that use the industrial standard 2-wire interface for communications. The IS24C08A and IS24C16A contain a memory array of 8K-bits (1,024x8) and 16K-bits (2,048x8), respectively. Each device is organized into 16 byte pages for page write mode.

This EEPROM operates in a wide voltage range of 2.7V to 3.6V to be compatible with most application voltages. ISSI designed this device family to be a practical, low-power 2-wire EEPROM solution. The devices are offered in Lead-free, RoHS, halogen free or Green. The available package types are 8-pin SOIC/SOP and TSSOP.

The IS24C08A/16A maintains compatibility with the popular 2-wire bus protocol, so it is easy to use in applications implementing this bus type. The simple bus consists of the Serial Clock wire (SCL) and the Serial Data wire (SDA). Using the bus, a Master device such as a microcontroller is usually connected to one or more Slave devices such as this device. The bit stream over the SDA line includes a series of bytes, which identifies a particular Slave device, an instruction, an address within that Slave device, and a series of data, if appropriate. The IS24C08A/16A has a Write Protect pin (WP) to allow blocking of any write instruction transmitted over the bus.

Copyright © 2008 Integrated Silicon Solution, Inc. All rights reserved. ISSI reserves the right to make changes to this specification and its products at any time without notice. ISSI products are not designed, intended, authorized or warranted for use as components in systems or equipment intended for critical medical or surgical equipment, aerospace systems, or for other applications planned to support or sustain life. It is the customer's obligation to optimize the design in their own products for the best performance and optimization on the functionality and etc. ISSI assumes no liability arising out of the application or use of any information, products or services described herein. Customers are advised to obtain the latest version of this device specification before relying on any published information and prior placing orders for products.

FUNCTIONAL BLOCK DIAGRAM

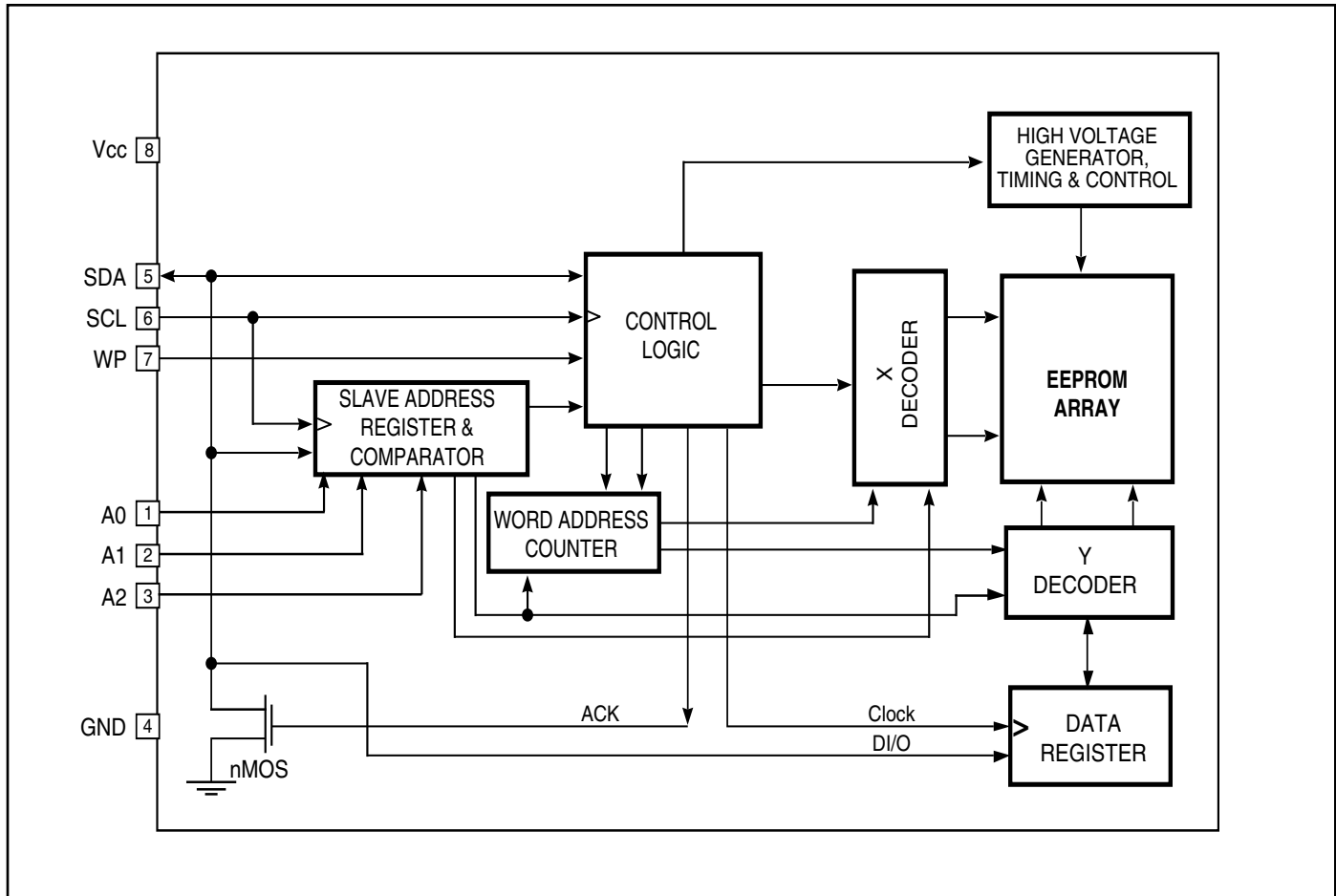

PIN CONFIGURATION

8-Pin SOIC & TSSOP

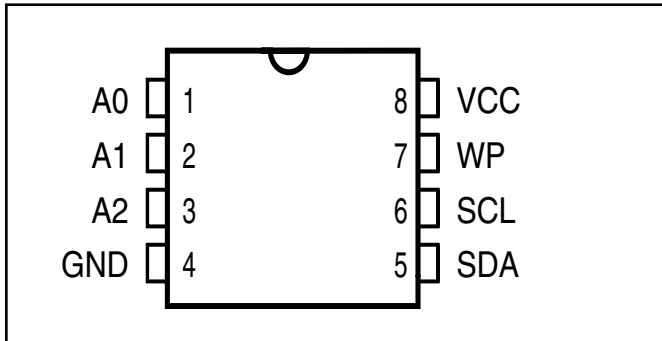

PIN DESCRIPTIONS

A0-A2	Address Inputs
SDA	Serial Address/Data I/O
SCL	Serial Clock Input
WP	Write Protect Input
Vcc	Power Supply
GND	Ground

SCL

This input clock pin is used to synchronize the data transfer to and from the device.

SDA

The SDA is a Bi-directional pin used to transfer addresses and data into and out of the device. The SDA pin is an open drain output and can be wire-Or'ed with other open drain or open collector outputs. The SDA bus *requires* a pullup resistor to Vcc.

A0, A1, A2

The A0, A1 and A2 are the device address inputs for hardware addressing. When the A0, A1, or A2 inputs are left floating, the input internally defaults to zero.

The IS24C08A only uses the A2 input for hardware addressing and a total of two devices may be addressed on a single bus system. The A0 and A1 pins are no connects in the IS24C08A. When the A2 input is left floating, the input internally defaults to zero.

These pins are not used by IS24C16A. The A0, A1, and A2 pins are no connects in the IS24C16A.

WP

WP is the Write Protect pin. If the WP pin is tied to Vcc on the IS24C08A and IS24C16A, the entire array becomes Write Protected (Read only). When WP is tied to GND or left floating normal read/write operations are allowed to the device.

DEVICE OPERATION

IS24C08A/16A features serial communication and supports a bi-directional 2-wire bus transmission protocol called I²C™.

2-WIRE BUS

The two-wire bus is defined as a Serial Data line (SDA), and a Serial Clock line (SCL). The protocol defines any device that sends data onto the SDA bus as a transmitter, and the receiving devices as receivers. The bus is controlled by Master device that generates the SCL, controls the bus access, and generates the Stop and Start conditions. The IS24C08A/16A is the Slave device on the bus.

The Bus Protocol:

- Data transfer may be initiated only when the bus is not busy
- During a data transfer, the SDA line must remain stable whenever the SCL line is high. Any changes in the SDA line while the SCL line is high will be interpreted as a Start or Stop condition.

The state of the SDA line represents valid data after a Start condition. The SDA line must be stable for the duration of the High period of the clock signal. The data on the SDA line may be changed during the Low period of the clock signal. There is one clock pulse per bit of data. Each data transfer is initiated with a Start condition and terminated with a Stop condition.

Start Condition

The Start condition precedes all commands to the device and is defined as a High to Low transition of SDA when SCL is High. The EEPROM monitors the SDA and SCL lines and will not respond until the Start condition is met.

Stop Condition

The Stop condition is defined as a Low to High transition of SDA when SCL is High. All operations must end with a Stop condition.

Acknowledge (ACK)

After a successful data transfer, each receiving device is required to generate an ACK. The Acknowledging device pulls down the SDA line.

Reset

The IS24C08A/16A contains a reset function in case the 2-wire bus transmission is accidentally interrupted (eg. a power loss), or needs to be terminated mid-stream. The reset is caused when the Master device creates a Start condition. To do this, it may be necessary for the Master device to monitor the SDA line while cycling the SCL up to nine times. (For each clock signal transition to High, the Master checks for a High level on SDA.)

Standby Mode

Power consumption is reduced in standby mode. The IS24C08A/16A will enter standby mode: a) At Power-up, and remain in it until SCL or SDA toggles; b) Following the Stop signal if a no write operation is initiated; or c) Following any internal write operation.

DEVICE ADDRESSING

The Master begins a transmission by sending a Start condition. The Master then sends the address of the particular Slave devices it is requesting. The Slave device (Fig. 5) address is 8 bits.

The four most significant bits of the Slave address are fixed as 1010 for the IS2408A/16A.

The next three bits of the Slave address are specific for each of the EEPROM. The bit values enable access to multiple memory blocks or multiple devices.

The IS24C08A uses the bits B0 and B1 to address one of the four 256 byte blocks in the device. Also, the bit A2 is used in a comparison with the hard-wired input value on the A2 pin. Up to two IS24C08A units may share the 2-wire bus.

The IS24C16A uses the bits B0, B1, and B2 to address one of the eight 256 byte blocks in the device.

The last bit of the Slave address specifies whether a Read or Write operation is to be performed. When this bit is set to 1, a Read operation is selected, and when set to 0, a Write operation is selected.

After the Master transmits the Start condition and Slave address byte (Fig. 5), the appropriate 2-wire Slave (eg. IS24C08A/16A) will respond with ACK on the SDA line. The Slave will pull down the SDA on the ninth clock cycle, signaling that it received the eight bits of data. The selected EEPROM then prepares for a Read or Write operation by monitoring the bus.

WRITE OPERATION

Byte Write

In the Byte Write mode, the Master device sends the Start condition and the Slave address information (with the R/\bar{W} set to Zero) to the Slave device. After the Slave generates an ACK, the Master sends the byte address that is to be written into the address pointer of the IS24C08A/16A. After receiving another ACK from the Slave, the Master device transmits the data byte to be written into the address memory location. The IS24C08A/16A acknowledges once more and the Master generates the Stop condition, at which time the device begins its internal programming cycle. While this internal cycle is in progress, the device will not respond to any request from the Master device.

Page Write

The IS24C08A/16A is capable of 16-byte Page-Write operation. A Page-Write is initiated in the same manner as a Byte Write, but instead of terminating the internal Write cycle after the first data word is transferred, the Master device can transmit up to 15 more bytes. After the receipt of each data word, the EEPROM responds immediately with an ACK on SDA line, and the four lower order data word address bits are internally incremented by one, while the higher order bits of the data word address remain constant. If a byte address is incremented from the last byte of a page, it returns to the first byte of that page. If the Master device should transmit more than 16 bytes prior to issuing the Stop condition, the address counter will “roll over,” and the previously written data will be overwritten. Once all 16 bytes are received and the Stop condition has been sent by the Master, the internal programming cycle begins. At this point, all received data is written to the IS24C08A/16A in a single Write cycle. All inputs are disabled until completion of the internal Write cycle.

Acknowledge (ACK) Polling

The disabling of the inputs can be used to take advantage of the typical Write cycle time. Once the Stop condition is issued to indicate the end of the host's Write operation, the IS24C08A/16A initiates the internal Write cycle. ACK polling can be initiated immediately. This involves issuing the Start condition followed by the Slave address for a Write operation. If the EEPROM is still busy with the Write operation, no ACK will be returned. If the IS24C08A/16A has completed the Write operation, an ACK will be returned and the host can then proceed with the next Read or Write operation.

READ OPERATION

Read operations are initiated in the same manner as Write operations, except that the (R/W) bit of the Slave address is set to "1". There are three Read operation options: current address read, random address read and sequential read.

Current Address Read

The IS24C08A/16A contains an internal address counter which maintains the address of the last byte accessed, incremented by one. For example, if the previous operation is either a Read or Write operation addressed to the address location n , the internal address counter would increment to address location $n+1$. When the EEPROM receives the Slave Addressing Byte with a Read operation (R/W bit set to "1"), it will respond an ACK and transmit the 8-bit data byte stored at address location $n+1$. The Master should not acknowledge the transfer but should generate a Stop condition so the IS24C08A/16A discontinues transmission. If 'n' is the last byte of the memory, the data from location '0' will be transmitted. (Refer to Figure 8. Current Address Read Diagram.)

Random Address Read

Selective Read operations allow the Master device to select at random any memory location for a Read operation. The Master device first performs a 'dummy' Write operation by sending the Start condition, Slave address and byte address of the location it wishes to read. After the IS24C08A/16A acknowledges the byte address, the Master device resends the Start condition and the Slave address, this time with the R/W bit set to one. The EEPROM then responds with its ACK and sends the data requested. The Master device does not send an ACK but will generate a Stop condition. (Refer to Figure 9. Random Address Read Diagram.)

Sequential Read

Sequential Reads can be initiated as either a Current Address Read or Random Address Read. After the IS24C08A/16A sends the initial byte sequence, the Master device now responds with an ACK indicating it requires additional data from the IS24C08A/16A. The EEPROM continues to output data for each ACK received. The Master device terminates the sequential Read operation by pulling SDA High (no ACK) indicating the last data word to be read, followed by a Stop condition.

The data output is sequential, with the data from address n followed by the data from address $n+1, n+2 \dots$ etc. The address counter increments by one automatically, allowing the entire memory contents to be serially read during sequential Read operation. When the memory address boundary of 255, 511, 1023, or 2047 (depending on the device) is reached, the address counter "rolls over" to address 0, and the device continues to output data. (Refer to Figure 10. Sequential Read Diagram).

FIGURE 1. TYPICAL SYSTEM BUS CONFIGURATION

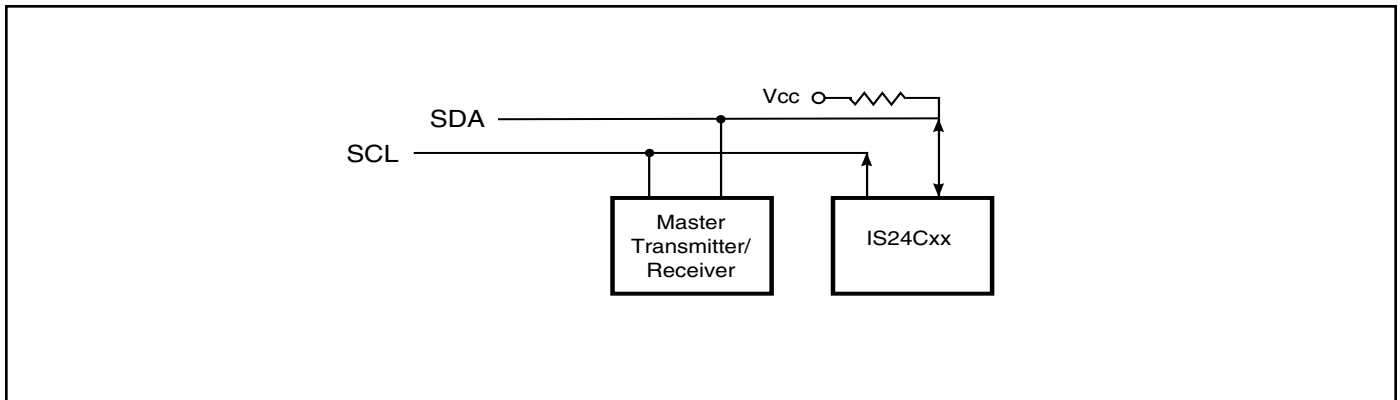

FIGURE 2. OUTPUT ACKNOWLEDGE

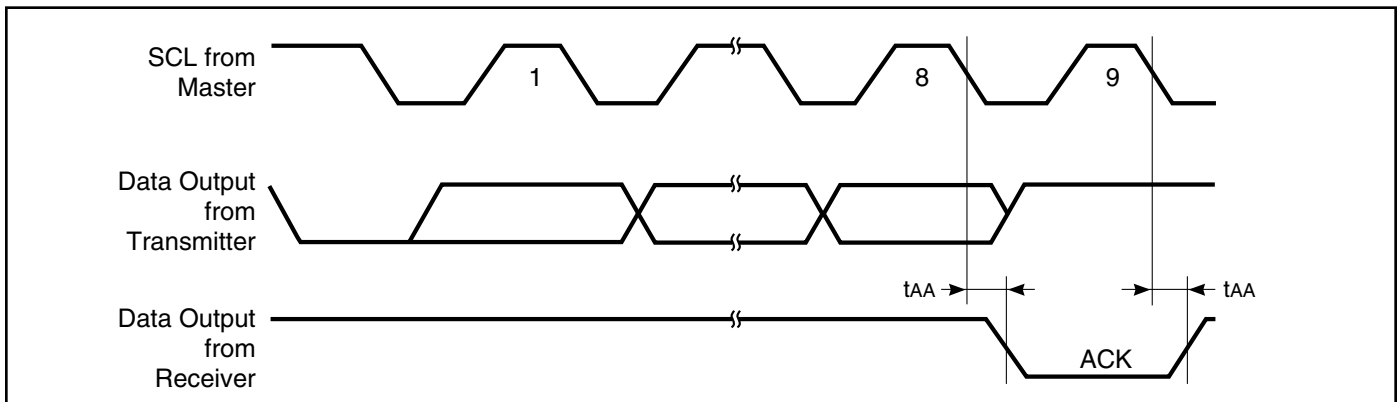

FIGURE 3. START AND STOP CONDITIONS

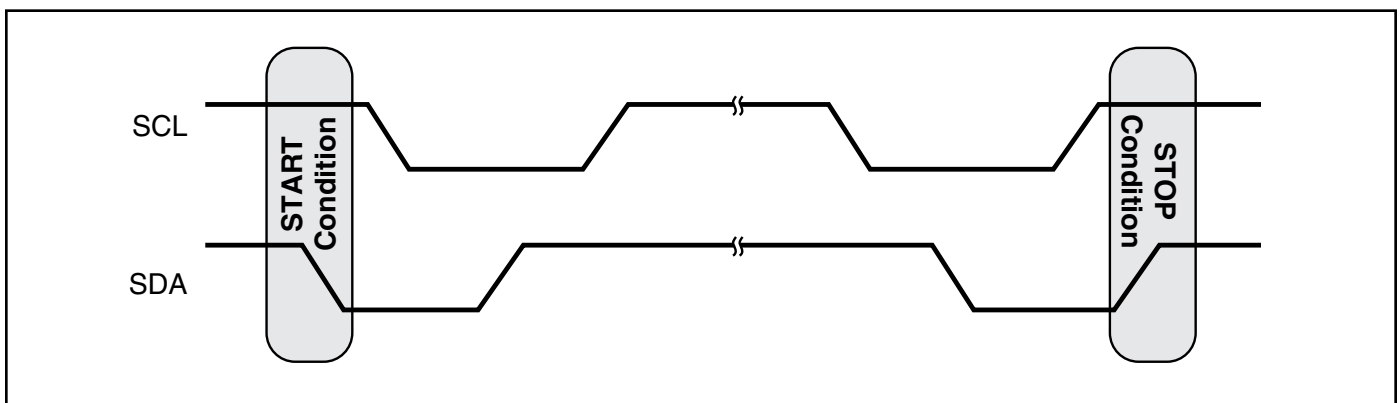

FIGURE 4. DATA VALIDITY PROTOCOL

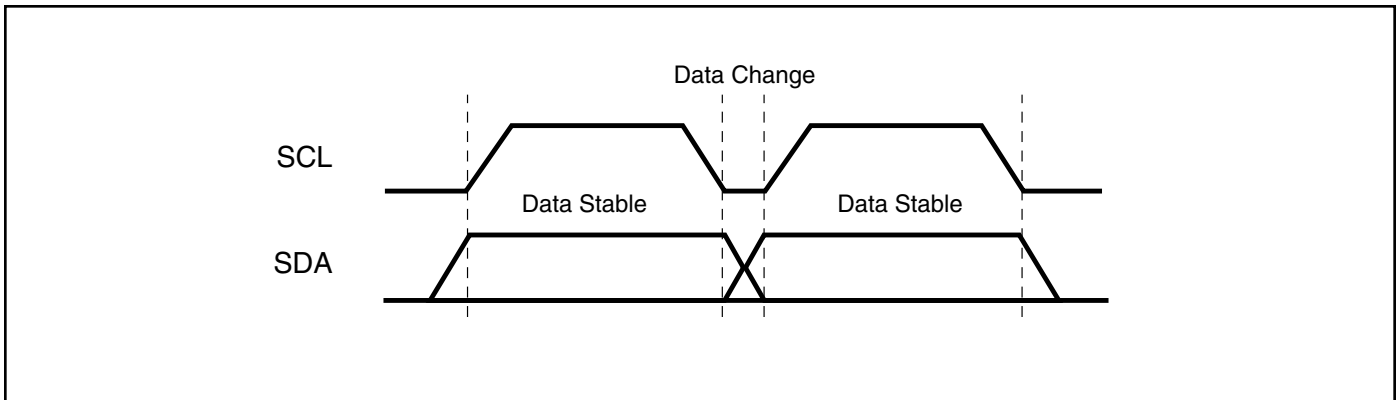

FIGURE 5. SLAVE ADDRESS

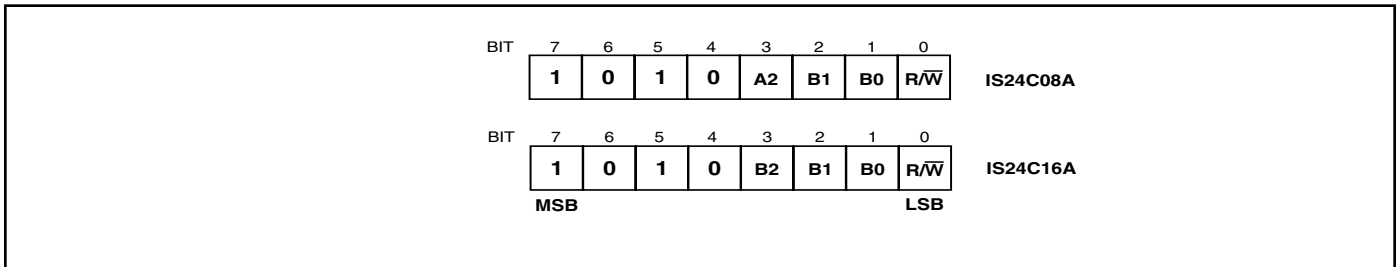

FIGURE 6. BYTE WRITE

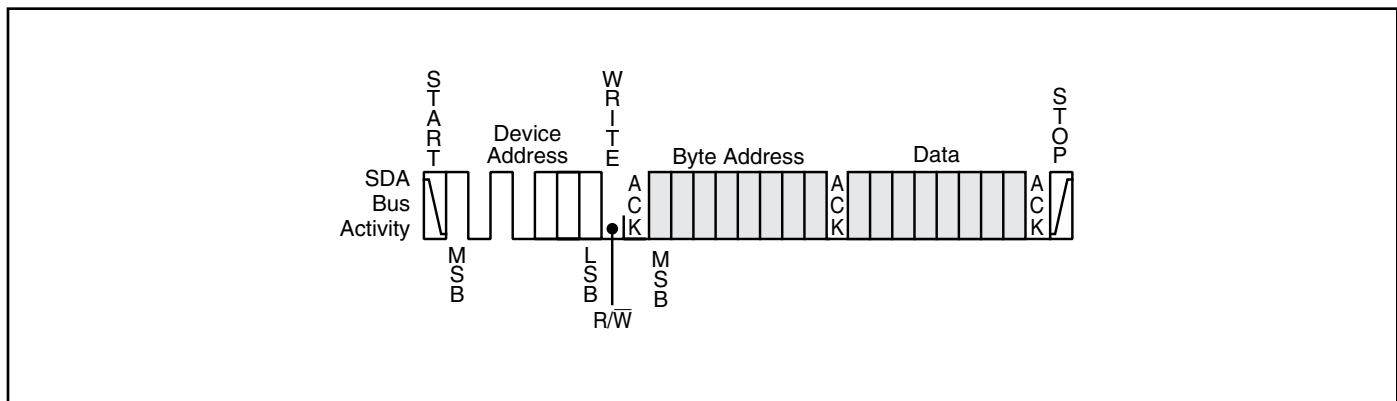

FIGURE 7. PAGE WRITE

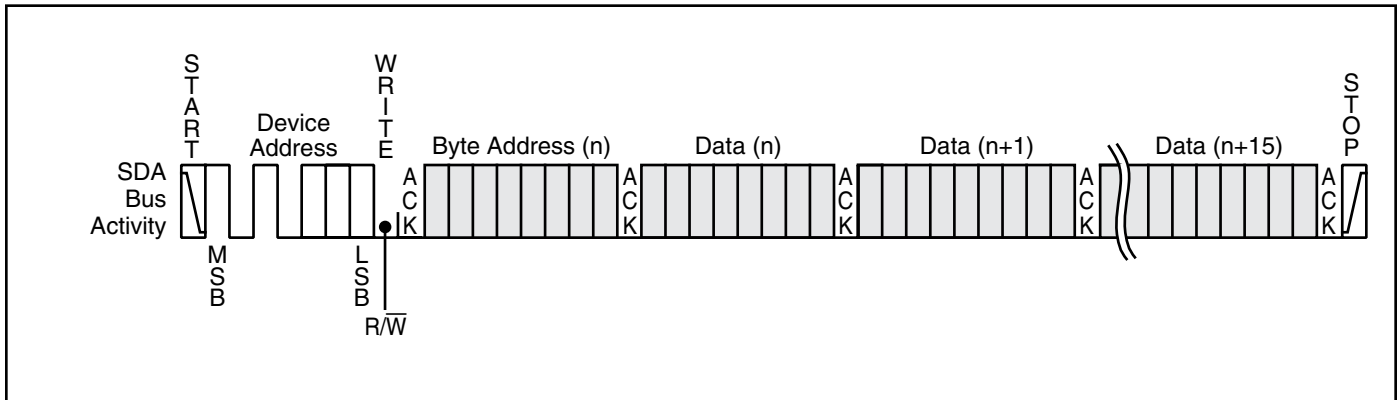

FIGURE 8. CURRENT ADDRESS READ

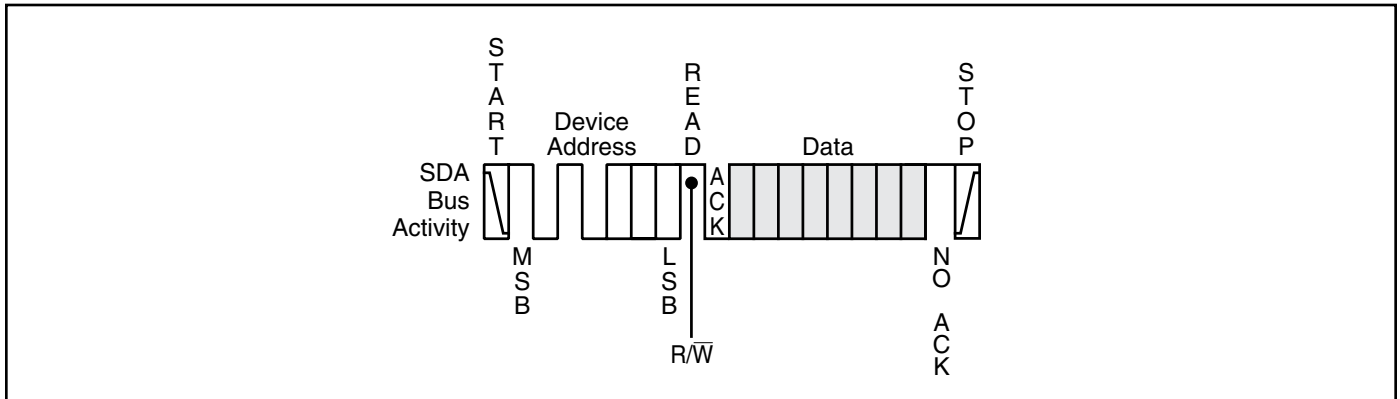

FIGURE 9. RANDOM ADDRESS READ

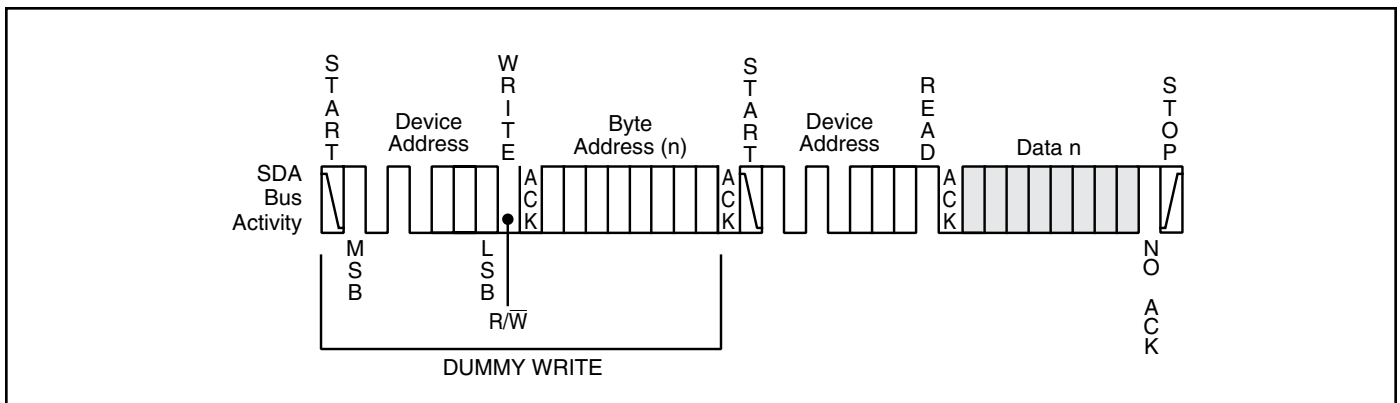
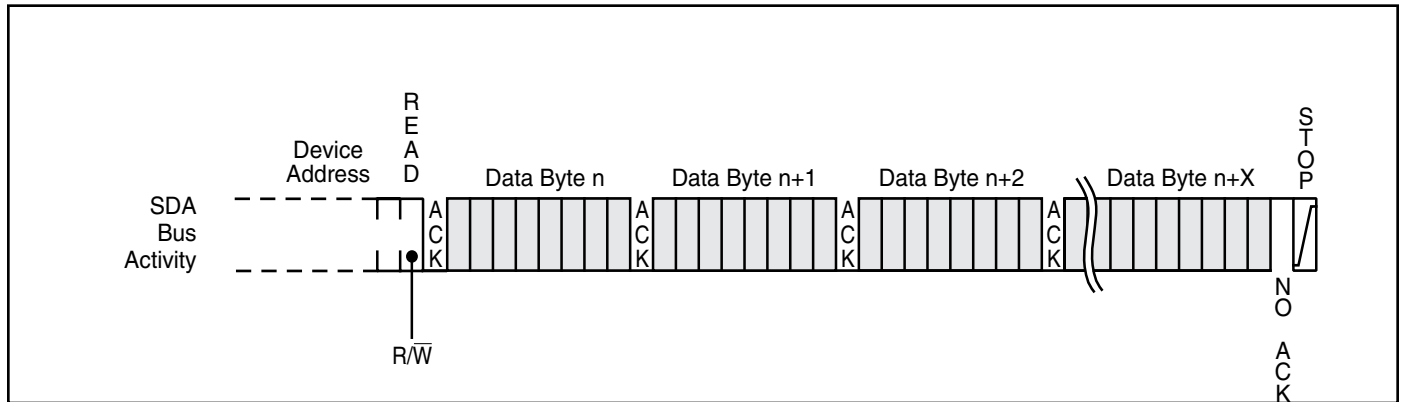

FIGURE 10. SEQUENTIAL READ



AC WAVEFORMS

Figure 11. Bus Timing

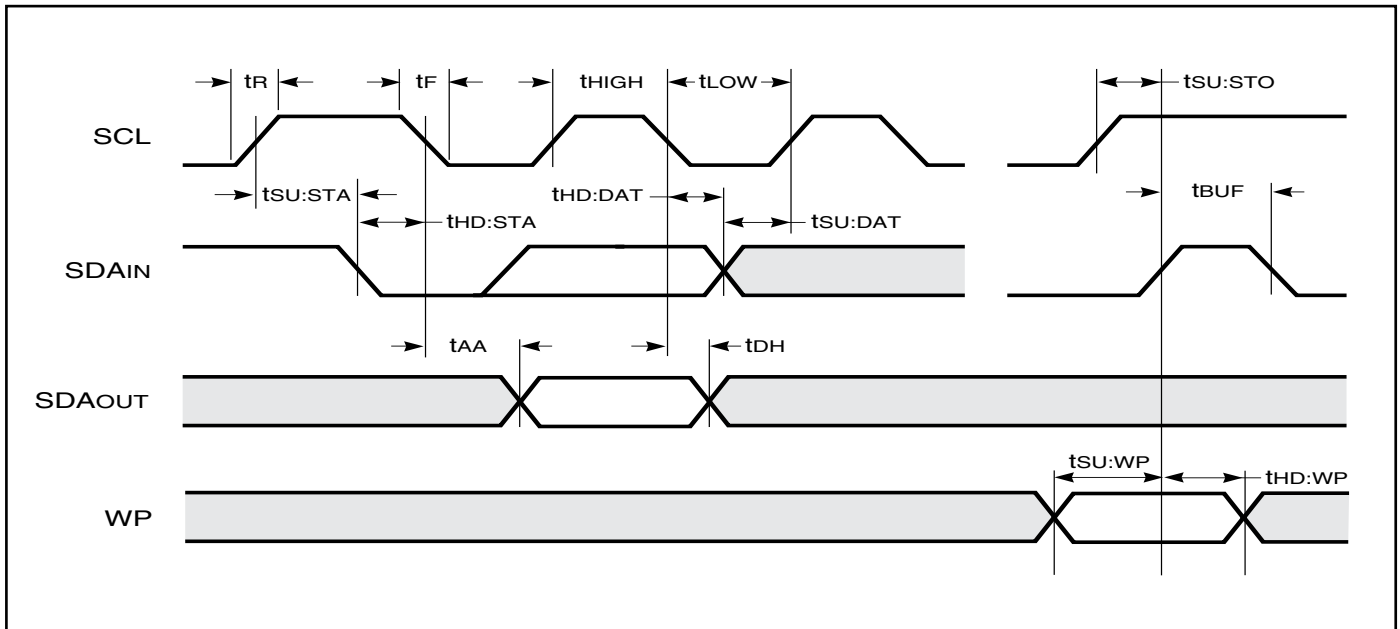
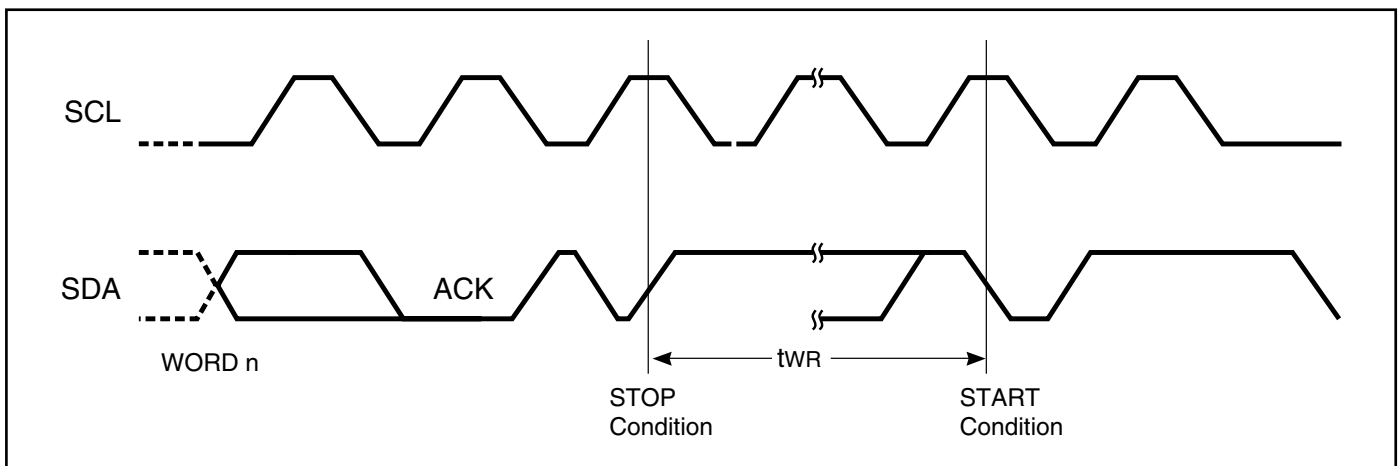

Figure 12. Write Cycle Timing



ABSOLUTE MAXIMUM RATINGS⁽¹⁾

Symbol	Parameter	Value	Unit
V _S	Supply Voltage	-0.5 to +6.5	V
V _P	Voltage on Any Pin	-0.5 to V _{CC} + 0.5	V
T _{BIAS}	Temperature Under Bias	-55 to +125	°C
T _{STG}	Storage Temperature	-65 to +150	°C
I _{OUT}	Output Current	5	mA

Notes:

1. Stress greater than those listed under ABSOLUTE MAXIMUM RATINGS may cause permanent damage to the device. This is a stress rating only and functional operation of the device at these or any other conditions above those indicated in the operational sections of this specification is not implied. Exposure to absolute maximum rating conditions for extended periods may affect reliability.

DC ELECTRICAL CHARACTERISTICS

 Automotive (T_A = -40°C to +85°C)

Symbol	Parameter	Test Conditions	Min.	Max.	Unit
I _{CC1}	Operating Current	Read at 400 KHz (V _{CC} = 3.3V)	—	2.0	mA
I _{CC2}	Operating Current	Write at 400 KHz (V _{CC} = 3.3V)	—	3.0	mA
I _{SB1}	Standby Current	V _{CC} = 3.3V	—	6	µA
V _{OL1}	Output Low Voltage	V _{CC} = 3.3V, I _{OL} = 0.15 mA	—	0.2	V
V _{OL2}	Output Low Voltage	V _{CC} = 3.3V, I _{OL} = 3 mA	—	0.4	V
V _{IH}	Input High Voltage		V _{CC} x 0.7	V _{CC} + 0.5	V
V _{IL}	Input Low Voltage		-1.0	V _{CC} x 0.3	V
I _{LI}	Input Leakage Current	V _{IN} = V _{CC} max.	—	3	µA
I _{LO}	Output Leakage Current		—	3	µA

Notes: V_{IL} min and V_{IH} max are reference only and are not tested.

CAPACITANCE^(1,2)

Symbol	Parameter	Conditions	Max.	Unit
C _{IN}	Input Capacitance	V _{IN} = 0V	6	pF
C _{OUT}	Output Capacitance	V _{OUT} = 0V	8	pF

Notes:

1. Tested initially and after any design or process changes that may affect these parameters.
2. Test conditions: T_A = 25°C, f = 400 KHz, V_{CC} = 3.3V.

AC ELECTRICAL CHARACTERISTICS

 Automotive (T_A = -40°C to +85°C)

		2.7V ≤ V_{CC} < 3.6V		
Symbol	Parameter⁽²⁾	Min.	Max.	Unit
f _{SCL}	SCL Clock Frequency	0	400	KHz
T	Noise Suppression Time ⁽¹⁾	—	50	ns
t _{LOW}	Clock Low Period	1.2	—	μs
t _{HIGH}	Clock High Period	0.6	—	μs
t _{BUF}	Bus Free Time Before New Transmission ⁽¹⁾	1.2	—	μs
t _{SU:STA}	Start Condition Setup Time	0.6	—	μs
t _{SU:STO}	Stop Condition Setup Time	0.6	—	μs
t _{HD:STA}	Start Condition Hold Time	0.6	—	μs
t _{SU:DAT}	Data In Setup Time	100	—	ns
t _{HD:DAT}	Data In Hold Time	0	—	ns
t _{SU:WP}	WP pin Setup Time	0.6	—	μs
t _{HD:WP}	WP pin Hold Time	1.2	—	μs
t _{DH}	Data Out Hold Time (SCL Low to SDA Data Out Change)	50	—	ns
t _{AA}	Clock to Output (SCL Low to SDA Data Out Valid)	50	900	ns
t _R	SCL and SDA Rise Time ⁽¹⁾	—	300	ns
t _F	SCL and SDA Fall Time ⁽¹⁾	—	300	ns
t _{WR}	Write Cycle Time	—	10	ms

Note:

1. This parameter is characterized but not 100% tested.
2. The timing is referenced to half V_{CC} level.

ORDERING INFORMATION**Automotive (A1) Grade*: -40°C to +85°C, Lead-free**

Voltage Range	Part Number*	Package Type* (8-pin)
2.7V to 3.6V	IS24C08A-3GLA1-TR	150-mil SOIC (JEDEC)
	IS24C08A-3ZLA1-TR	3 x 4.4 mm TSSOP
2.7V to 3.6V	IS24C16A-3GLA1-TR	150-mil SOIC (JEDEC)
	IS24C16A-3ZLA1-TR	3 x 4.4 mm TSSOP

*

1. Contact ISSI Sales Representatives for availability and other package information.
2. The listed part numbers are packed in tape and reel "-TR" (4K per reel). UDFN/DFN is 5K per reel.
3. For tube/bulk packaging, remove "-TR" at the end of the P/N.
4. Refer to ISSI website for related declaration document on lead free, RoHS, halogen free, or Green, whichever is applicable.

SYMBOL	DIMENSION IN MM			DIMENSION IN INCH		
	MIN.	NOM.	MAX.	MIN.	NOM.	MAX.
A	1.35		1.75	0.053		0.069
A1	0.10		0.25	0.004		0.010
b	0.33		0.51	0.013		0.020
D	4.80		5.00	0.189		0.197
E	5.80		6.20	0.228		0.244
E1	3.80		4.00	0.150		0.157
e	1.27 BSC.			0.050 BSC.		
L	0.38		1.27	0.015		0.050
L1	0.25 BSC.			0.010 BSC.		
ZD	0.545 REF.			0.021 REF.		
ϕ	0		8°	0		8°

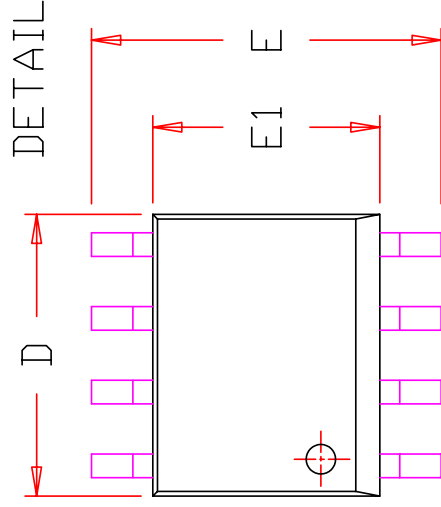
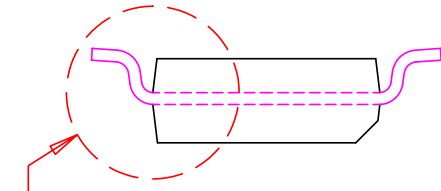

ZD

NOTE :

1. CONTROLLING DIMENSION : MM
2. DIMENSION D AND E1 DO NOT INCLUDE MOLD PROTRUSION.
3. DIMENSION b DOES NOT INCLUDE DAMBAR PROTRUSION/INTRUSION.

DETAIL A

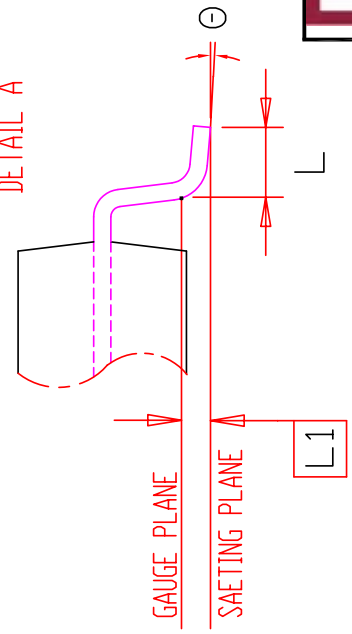

	TITLE	REV.	DATE
	8L 150mil SOP Package Outline	C	07/30/2009

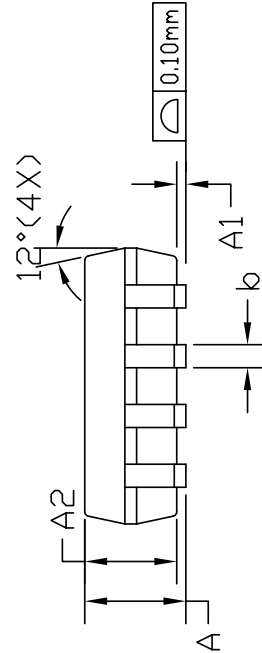
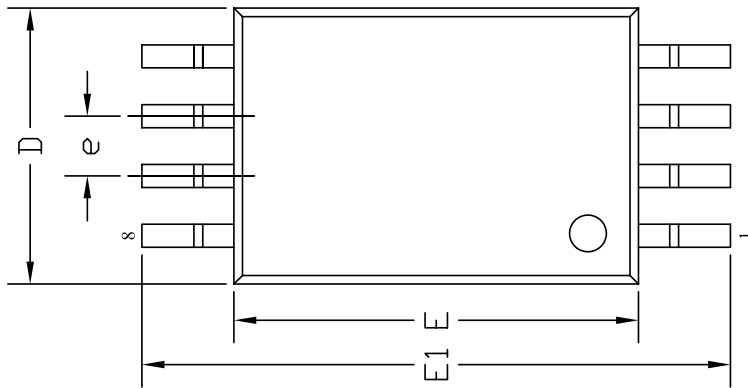
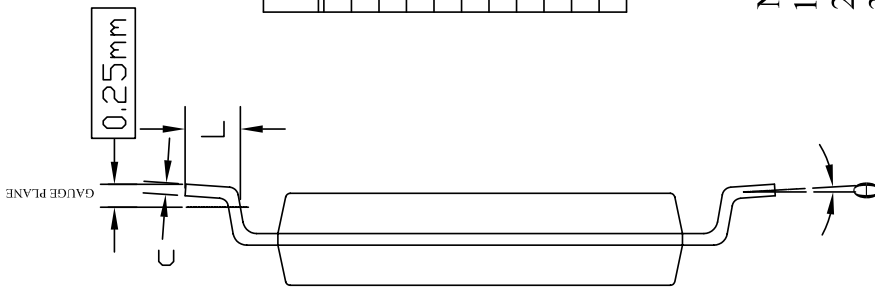

SYMBOLS	DIMENSIONS IN MILLIMETERS			DIMENSIONS IN INCHES		
	MIN	NOM	MAX	MIN	NOM	MAX
A	---	---	1.20	---	---	0.047
A1	0.05	---	0.15	0.002	---	0.006
A2	0.80	1.00	1.05	0.031	0.039	0.041
b	0.19	---	0.30	0.007	---	0.012
c	0.09	---	0.20	0.004	---	0.008
D	2.90	3.00	3.10	0.114	0.118	0.122
E1	6.40 BSC			0.252 BSC		
E	4.30	4.40	4.50	0.169	0.173	0.177
e	0.65 BSC			0.026 BSC		
L	0.45	0.60	0.75	0.018	0.024	0.030
θ	0°	---	8°	0°	---	8°

NOTE

1. CONTROLLING DIMENSION IS MILLIMETER.
2. REFER TO JEDEC STANDARD MO-153 AA.
3. PACKAGE MAY HAVE EXPOSED TIE BAR.
4. DIMENSION "D" AND "E1" DOES NOT INCLUDE MOLD PROTRUSION.
5. DIMENSION "b" DOES NOT INCLUDE DAM BAR PROTRUSION.



TITLE

8L 3x4.4mm TSSOP
Package Outline

REV. A

DATE

5/11/2009