

36 Mb (1M x 36 & 2M x 18) DDR-II (Burst of 4) CIO Synchronous SRAMs



JANUARY 2009

Features

- 1M x 36 or 2M x 18.
- On-chip delay-locked loop (DLL) for wide data valid window.
- Common I/O read and write ports.
- Synchronous pipeline read with late write operation.
- Double data rate (DDR-II) interface for read and write input ports.
- Fixed 4-bit burst for read and write operations.
- Clock stop support.
- Two input clocks (K and \bar{K}) for address and control registering at rising edges only.
- Two input clocks (C and \bar{C}) for data output control.
- Two echo clocks (CQ and \bar{CQ}) that are delivered simultaneously with data.
- +1.8V core power supply and 1.5, 1.8V V_{DDQ} , used with 0.75, 0.9V V_{REF}
- HSTL input and output levels.
- Registered addresses, write and read controls, byte writes, and data outputs.
- Full data coherency.
- Boundary scan using limited set of JTAG 1149.1 functions.
- Byte write capability.
- Fine ball grid array (FBGA) package
 - 15mm x 17mm body size
 - 1mm pitch
 - 165-ball (11 x 15) array
- Programmable impedance output drivers via 5x user-supplied precision resistor.

Description

The 36Mb IS61DDB41M36 and IS61DDB42M18 are synchronous, high-performance CMOS static random access memory (SRAM) devices. These SRAMs have a common I/O bus. The rising edge of K clock initiates the read/write operation, and all internal operations are self-timed. Refer to the *Timing Reference Diagram for Truth Table on p.8* for a description of the basic operations of these DDR-II (Burst of 4) CIO SRAMs.

Read and write addresses are registered on alternating rising edges of the K clock. Reads and writes are performed in double data rate. The following are registered internally on the rising edge of the K clock:

- Read and write addresses
- Address load
- Read/write enable
- Byte writes for burst addresses 1 and 3
- Data-in for burst addresses 1 and 3

The following are registered on the rising edge of the \bar{K} clock:

- Byte writes for burst addresses 2 and 4

- Data-in for burst addresses 2 and 4

Byte writes can change with the corresponding data-in to enable or disable writes on a per-byte basis. An internal write buffer enables the data-ins to be registered one cycle later than the write address. The first data-in burst is clocked one cycle later than the write command signal, and the second burst is timed to the following rising edge of the \bar{K} clock. Two full clock cycles are required to complete a write operation.

During the burst read operation, at the first and third bursts the data-outs are updated from output registers off the second and fourth rising edges of the \bar{C} clock (starting 1.5 cycles later). At the second and fourth bursts, the data-outs are updated with the third and fifth rising edges of the corresponding C clock (see page 9). The K and \bar{K} clocks are used to time the data-outs whenever the C and \bar{C} clocks are tied high. Two full clock cycles are required to complete a read operation

The device is operated with a single +1.8V power supply and is compatible with HSTL I/O interfaces.

x36 FBGA Pinout (Top View)

	1	2	3	4	5	6	7	8	9	10	11
A	\overline{CQ}	V_{SS}/SA^*	SA	R/\overline{W}	\overline{BW}_2	\overline{K}	\overline{BW}_1	\overline{LD}	SA	V_{SS}/SA^*	CQ
B	NC	DQ27	DQ18	SA	\overline{BW}_3	K	\overline{BW}_0	SA	NC	NC	DQ8
C	NC	NC	DQ28	V_{SS}	SA	SA_0	SA_1	V_{SS}	NC	DQ17	DQ7
D	NC	DQ29	DQ19	V_{SS}	V_{SS}	V_{SS}	V_{SS}	V_{SS}	NC	NC	DQ16
E	NC	NC	DQ20	V_{DDQ}	V_{SS}	V_{SS}	V_{SS}	V_{DDQ}	NC	DQ15	DQ6
F	NC	DQ30	DQ21	V_{DDQ}	V_{DD}	V_{SS}	V_{DD}	V_{DDQ}	NC	NC	DQ5
G	NC	DQ31	DQ22	V_{DDQ}	V_{DD}	V_{SS}	V_{DD}	V_{DDQ}	NC	NC	DQ14
H	\overline{Doff}	V_{REF}	V_{DDQ}	V_{DDQ}	V_{DD}	V_{SS}	V_{DD}	V_{DDQ}	V_{DDQ}	V_{REF}	ZQ
J	NC	NC	DQ32	V_{DDQ}	V_{DD}	V_{SS}	V_{DD}	V_{DDQ}	NC	DQ13	DQ4
K	NC	NC	DQ23	V_{DDQ}	V_{DD}	V_{SS}	V_{DD}	V_{DDQ}	NC	DQ12	DQ3
L	NC	DQ33	DQ24	V_{DDQ}	V_{SS}	V_{SS}	V_{SS}	V_{DDQ}	NC	NC	DQ2
M	NC	NC	DQ34	V_{SS}	V_{SS}	V_{SS}	V_{SS}	V_{SS}	NC	DQ11	DQ1
N	NC	DQ35	DQ25	V_{SS}	SA	SA	SA	V_{SS}	NC	NC	DQ10
P	NC	NC	DQ26	SA	SA	C	SA	SA	NC	DQ9	DQ0
R	TDO	TCK	SA	SA	SA	\overline{C}	SA	SA	SA	TMS	TDI

- The following pins are reserved for higher densities: 2A for 144Mb, 10A for 72Mb.
- \overline{BW}_0 controls writes to DQ0–DQ8; \overline{BW}_1 controls writes to DQ9–DQ17; \overline{BW}_2 controls writes to DQ18–DQ26; \overline{BW}_3 controls writes to DQ27–DQ35.

x18 FBGA Pinout (Top View)

	1	2	3	4	5	6	7	8	9	10	11
A	\overline{CQ}	V_{SS}/SA^*	SA	R/\overline{W}	\overline{BW}_1	\overline{K}	NC/SA	\overline{LD}	SA	SA	CQ
B	NC	DQ9	NC	SA	NC/SA	K	\overline{BW}_0	SA	NC	NC	DQ8
C	NC	NC	NC	V_{SS}	SA	SA_0	SA_1	V_{SS}	NC	DQ7	NC
D	NC	NC	DQ10	V_{SS}	V_{SS}	V_{SS}	V_{SS}	V_{SS}	NC	NC	NC
E	NC	NC	DQ11	V_{DDQ}	V_{SS}	V_{SS}	V_{SS}	V_{DDQ}	NC	NC	DQ6
F	NC	DQ12	NC	V_{DDQ}	V_{DD}	V_{SS}	V_{DD}	V_{DDQ}	NC	NC	DQ5
G	NC	NC	DQ13	V_{DDQ}	V_{DD}	V_{SS}	V_{DD}	V_{DDQ}	NC	NC	NC
H	\overline{Doff}	V_{REF}	V_{DDQ}	V_{DDQ}	V_{DD}	V_{SS}	V_{DD}	V_{DDQ}	V_{DDQ}	V_{REF}	ZQ
J	NC	NC	NC	V_{DDQ}	V_{DD}	V_{SS}	V_{DD}	V_{DDQ}	NC	DQ4	NC
K	NC	NC	DQ14	V_{DDQ}	V_{DD}	V_{SS}	V_{DD}	V_{DDQ}	NC	NC	DQ3
L	NC	DQ15	NC	V_{DDQ}	V_{SS}	V_{SS}	V_{SS}	V_{DDQ}	NC	NC	DQ2
M	NC	NC	NC	V_{SS}	V_{SS}	V_{SS}	V_{SS}	V_{SS}	NC	DQ1	NC
N	NC	NC	DQ16	V_{SS}	SA	SA	SA	V_{SS}	NC	NC	NC
P	NC	NC	DQ17	SA	SA	C	SA	SA	NC	NC	DQ0
R	TDO	TCK	SA	SA	SA	\overline{C}	SA	SA	SA	TMS	TDI

- The following pin is reserved for higher densities: 2A for 72Mb, 7A for 144Mb, 5B for 288Mb.
- \overline{BW}_0 controls writes to DQ0–DQ8; \overline{BW}_1 controls writes to DQ9–DQ17

Pin Description

Symbol	Pin Number	Description
K, \bar{K}	6B, 6A	Input clock.
C, \bar{C}	6P, 6R	Input clock for output data control.
CQ, \bar{CQ}	11A, 1A	Output echo clock.
\bar{Doff}	1H	DLL disable when low.
SA ₀ , SA ₁	6C, 7C	Burst count address inputs.
SA	9A, 4B, 8B, 5C, 5N, 6N, 7N, 4P, 5P, 7P, 8P, 3R, 4R, 5R, 7R, 8R, 9R	1M x 36 address inputs.
SA	3A, 9A, 4B, 8B, 5C, 5N, 6N, 7N, 4P, 5P, 7P, 8P, 3R, 4R, 5R, 7R, 8R, 9R	2M x 18 address inputs.
DQ0–DQ8 DQ9–DQ17 DQ18–DQ26 DQ27–DQ35	11P, 11M, 11L, 11K, 11J, 11F, 11E, 11C, 11B 10P, 11N, 10M, 10K, 10J, 11G, 10E, 11D, 10C 3B, 3D, 3E, 3F, 3G, 3K, 3L, 3N, 3P 2B, 3C, 2D, 2F, 2G, 3J, 2L, 3M, 2N	1M x 36 DQ pins
DQ0–DQ8 DQ9–DQ17	11P, 10M, 11L, 11K, 10J, 11F, 11E, 10C, 11B 2B, 3D, 3E, 2F, 3G, 3K, 2L, 3N, 3P	2M x 18 DQ pins
R/ \bar{W}	4A	Read/write control. Read when active high.
\bar{LD}	8A	Synchronizes load. Loads new address when low.
$\bar{BW}_0, \bar{BW}_1, \bar{BW}_2, \bar{BW}_3$	7B, 7A, 5A, 5B	1M x 36 byte write control, active low.
\bar{BW}_0, \bar{BW}_1	7B, 5A	2M x 18 byte write control, active low.
V _{REF}	2H, 10H	Input reference level.
V _{DD}	5F, 7F, 5G, 7G, 5H, 7H, 5J, 7J, 5K, 7K	Power supply.
V _{DDQ}	4E, 8E, 4F, 8F, 4G, 8G, 3H, 4H, 8H, 9H, 4J, 8J, 4K, 8K, 4L, 8L	Output power supply.
V _{SS}	2A, 10A, 4C, 8C, 4D, 5D, 6D, 7D, 8D, 5E, 6E, 7E, 6F, 6G, 6H, 6J, 6K, 5L, 6L, 7L, 4M, 8M, 4N, 8N	Power supply.
ZQ	11H	Output driver impedance control.
TMS, TDI, TCK	10R, 11R, 2R	IEEE 1149.1 test inputs (1.8V LVTTTL levels).
TDO	1R	IEEE 1149.1 test output (1.8V LVTTTL level).

Block Diagram

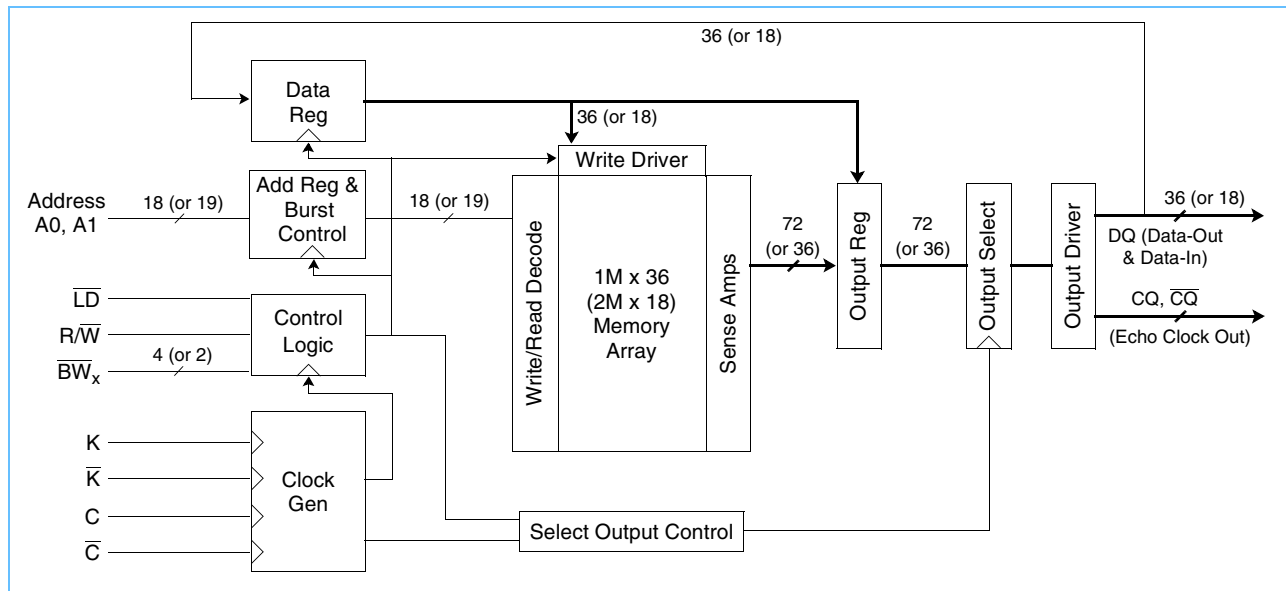

SRAM Features

Read Operations

The SRAM operates continuously in a burst-of-four mode. Read cycles are started by registering R/\bar{W} in active high state at the rising edge of the K clock. R/\bar{W} can be activated every other cycle because two full cycles are required to complete the burst-of-four read in DDR mode. A second set of clocks, C and \bar{C} , are used to control the timing to the outputs. A set of free-running echo clocks, CQ and \bar{CQ} , are produced internally with timings identical to the data-outs. The echo clocks can be used as data capture clocks by the receiver device.

When the C and \bar{C} clocks are connected high, the K and \bar{K} clocks assume the function of those clocks. In this case, the data corresponding to the first address is clocked 1.5 cycles later by the rising edge of the \bar{K} clock. The data corresponding to the second burst is clocked 2 cycles later by the following rising edge of the K clock. The third data-out is clocked by the subsequent rising edge of the \bar{K} clock, and the fourth data-out is clocked by the subsequent rising edge of the K clock.

Whenever \bar{LD} is low, a new address is registered at the rising edge of the K clock. A NOP operation (\bar{LD} is high) does not terminate the previous read. The output drivers disable automatically to a high state.

Write Operations

Write operations can also be initiated at every other rising edge of the K clock whenever R/\bar{W} is low. The write address is also registered at that time. When the address needs to change, \bar{LD} needs to be low simultaneously to be registered by the rising edge of K. Again, the write always occurs in bursts of four.

The write data is provided in a 'late write' mode; that is, the data-in corresponding to the first address of the burst, is presented 1 cycle later or at the rising edge of the following K clock. The data-in corresponding to the second write burst address follows next, registered by the rising edge of \bar{K} . The third data-out is clocked by the subsequent rising edge of the K clock, and the fourth data-out is clocked by the subsequent rising edge of the \bar{K} clock.

The data-in provided for writing is initially kept in write buffers. The information on these buffers is written into the array on the third write cycle. A read cycle to the last two write address produces data from the write buffers. The SRAM maintains data coherency.

During a write, the byte writes independently control which byte of any of the four burst addresses is written (see *X18/X36 Write Truth Tables* on page 9 and *Timing Reference Diagram for Truth Table* on page 8).

Whenever a write is disabled (R/\bar{W} is high at the rising edge of K), data is not written into the memory.

RQ Programmable Impedance

An external resistor, RQ, must be connected between the ZQ pin on the SRAM and V_{SS} to enable the SRAM to adjust its output driver impedance. The value of RQ must be 5x the value of the intended line impedance driven by the SRAM. For example, an RQ of 250 Ω results in a driver impedance of 50 Ω . The allowable range of RQ to guarantee impedance matching is between 175 Ω and 350 Ω , with the tolerance described in *Programmable Impedance Output Driver DC Electrical Characteristics* on page 15. The RQ resistor should be placed less than two inches away from the ZQ ball on the SRAM module. The capacitance of the loaded ZQ trace must be less than 3 pF.

The ZQ pin can also be directly connected to V_{DDQ} to obtain a minimum impedance setting. ZQ must never be connected to V_{SS} .

Programmable Impedance and Power-Up Requirements

Periodic readjustment of the output driver impedance is necessary as the impedance is greatly affected by drifts in supply voltage and temperature. At power-up, the driver impedance is in the middle of allowable impedances values. The final impedance value is achieved within 1024 clock cycles.

Clock Consideration

This device uses an internal DLL for maximum output data valid window. It can be placed in a stopped-clock mode to minimize power and requires only 1024 cycles to restart.

No clocks can be issued until V_{DD} reaches its allowable operating range.

Single Clock Mode

This device can be also operated in single-clock mode. In this case, C and \bar{C} are both connected high at power-up and must never change. Under this condition, K and \bar{K} control the output timings.

Either clock pair must have both polarities switching and must never connect to V_{REF} , as they are not differential clocks.

State Diagram

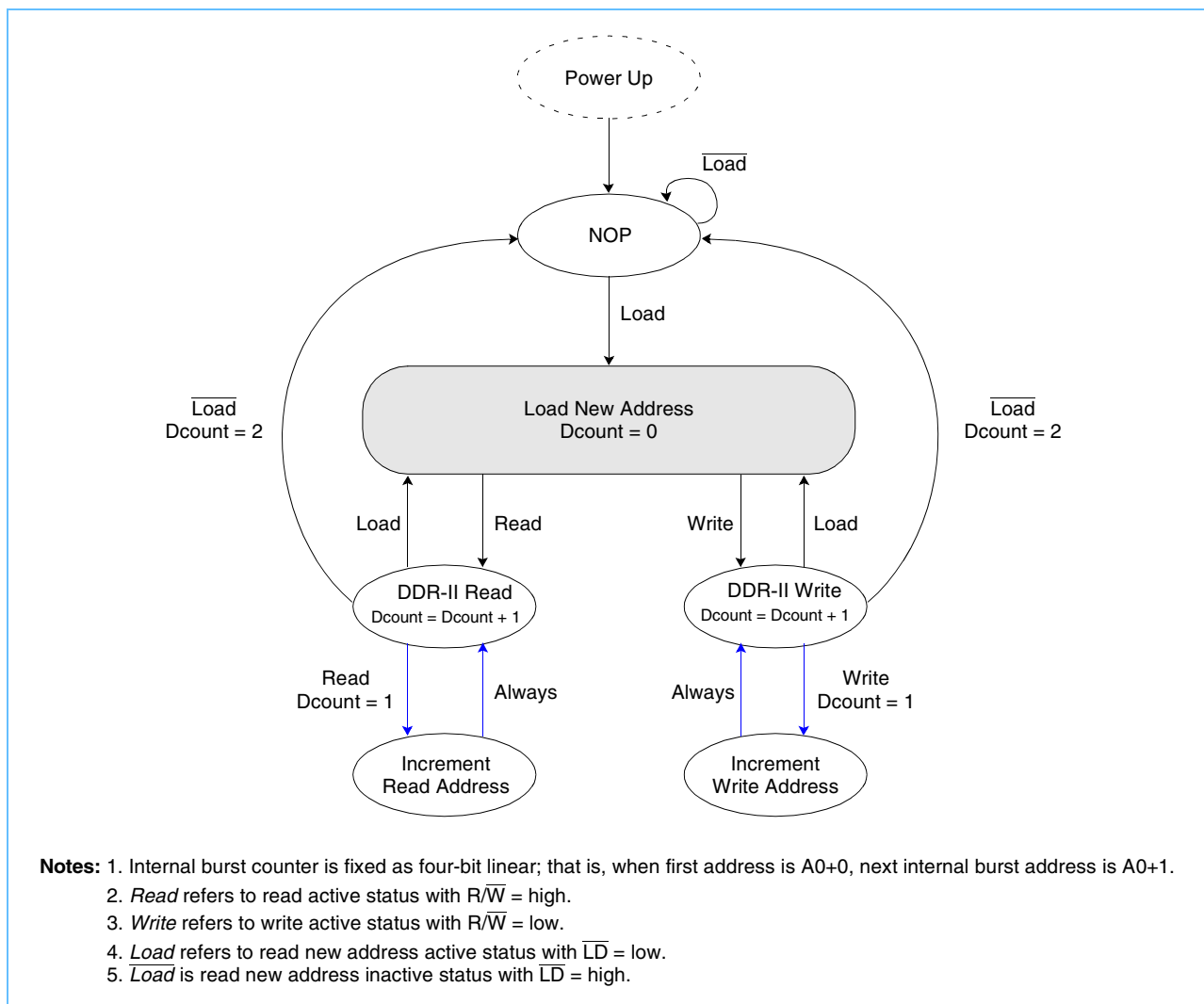

The *Timing Reference Diagram for Truth Table* on page 8 is helpful in understanding the clock and write truth tables, as it shows the cycle relationship between clocks, address, data-in, data-out, and controls. All read and write commands are issued at the beginning of cycles t and t_w , respectively.

Linear Burst Sequence Table

Burst Sequence	Case 1		Case 2		Case 3		Case 4	
	SA ₁	SA ₀	SA ₁	SA ₀	SA ₁	SA ₀	SA ₁	SA ₀
First Address	0	0	0	1	1	0	1	1
Second Address	0	1	1	0	1	1	0	0
Third Address	1	0	1	1	0	0	0	1
Fourth Address	1	1	0	0	0	1	1	0

Timing Reference Diagram for Truth Table

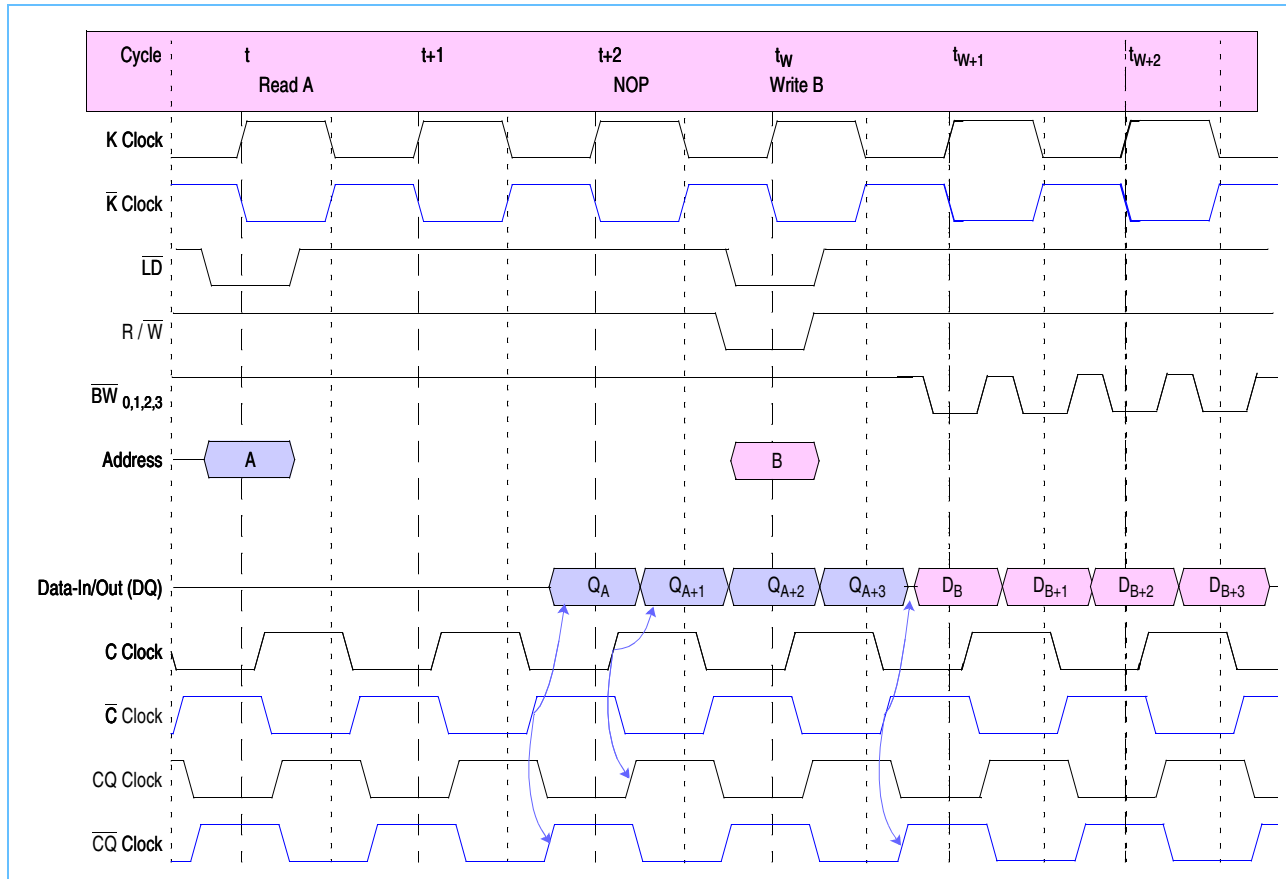

Clock Truth Table (Use the following table with the *Timing Reference Diagram for Truth Table*.)

Mode	Clock	Controls		Data Out / Data In			
	K	\overline{LD}	R/\overline{W}	Q_A / D_B	Q_{A+1} / D_{B+1}	Q_{A+2} / D_{B+2}	Q_{A+3} / D_{B+3}
Stop Clock	Stop	X	X	Previous State	Previous State	Previous State	Previous State
No Operation (NOP)	L→H	H	H	High-Z	High-Z	High-Z	High-Z
Read B	L→H	L	H	Dout at \overline{C} (t + 1.5)	Dout at C (t + 2)	Dout at \overline{C} (t + 2.5)	Dout at C (t + 3)
Write A	L→H	L	L	D_B ($t_W + 1$)	D_B ($t_W + 1.5$)	D_B ($t_W + 2$)	D_B ($t_W + 2.5$)

Notes:

1. The internal burst counter is always fixed as two-bit.
2. X = don't care; H = logic "1"; L = logic "0".
3. A read operation is started when control signal R/\overline{W} is active high.
4. A write operation is started when control signal R/\overline{W} is active low.
5. Before entering into the stop clock, all pending read and write commands must be completed.
6. For timing definitions, refer to the *AC Characteristics* on page 16. Signals must have AC specifications at timings indicated in parenthesis with respect to switching clocks K, \overline{K} , C, and \overline{C} .

36 Mb (1M x 36 & 2M x 18) DDR-II (Burst of 4) CIO Synchronous SRAMs

X36 Write Truth Table Use the following table with the *Timing Reference Diagram for Truth Table* on page 8.

Operation	K (t_{W+1})	\bar{K} ($t_{W+1.5}$)	K (t_{W+2})	\bar{K} ($t_{W+2.5}$)	\overline{BW}_0	\overline{BW}_1	\overline{BW}_2	\overline{BW}_3	D _B	D _{B+1}	D _{B+2}	D _{B+3}
Write Byte 0	L→H				L	H	H	H	D0-8 (t_{W+1})			
Write Byte 1	L→H				H	L	H	H	D9-17 (t_{W+1})			
Write Byte 2	L→H				H	H	L	H	D18-26 (t_{W+1})			
Write Byte 3	L→H				H	H	H	L	D27-35 (t_{W+1})			
Write All Bytes	L→H				L	L	L	L	D0-35 (t_{W+1})			
Abort Write	L→H				H	H	H	H	Don't care			
Write Byte 0		L→H			L	H	H	H		D0-8 ($t_{W+1.5}$)		
Write Byte 1		L→H			H	L	H	H		D9-17 ($t_{W+1.5}$)		
Write Byte 2		L→H			H	H	L	H		D18-26 ($t_{W+1.5}$)		
Write Byte 3		L→H			H	H	H	L		D27-35 ($t_{W+1.5}$)		
Write All Bytes		L→H			L	L	L	L		D0-35 ($t_{W+1.5}$)		
Abort Write		L→H			H	H	H	H		Don't care		
Write Byte 0			L→H		L	H	H	H			D0-8 (t_{W+2})	
Write Byte 1			L→H		H	L	H	H			D9-17 (t_{W+2})	
Write Byte 2			L→H		H	H	L	H			D18-26 (t_{W+2})	
Write Byte 3			L→H		H	H	H	L			D27-35 (t_{W+2})	
Write All Bytes			L→H		L	L	L	L			D0-35 (t_{W+2})	
Abort Write			L→H		H	H	H	H			Don't care	
Write Byte 0				L→H	L	H	H	H				D0-8 ($t_{W+2.5}$)
Write Byte 1				L→H	H	L	H	H				D9-17 ($t_{W+2.5}$)
Write Byte 2				L→H	H	H	L	H				D18-26 ($t_{W+2.5}$)
Write Byte 3				L→H	H	H	H	L				D27-35 ($t_{W+2.5}$)
Write All Bytes				L→H	L	L	L	L				D0-35 ($t_{W+2.5}$)
Abort Write				L→H	H	H	H	H				Don't care

Notes:

1. For all cases, $\overline{R/\overline{W}}$ needs to be active low during the rising edge of K occurring at time t_W
2. For timing definitions refer to the *AC Characteristics* on page 16. Signals must have AC specifications with respect to switching clocks \bar{K} and K.



X18 Write Truth Table Use the following table with the *Timing Reference Diagram for Truth Table* on page 8.

Operation	K (t_{W+1})	\bar{K} ($t_{W+1.5}$)	K (t_{W+2})	\bar{K} ($t_{W+2.5}$)	\overline{BW}_0	\overline{BW}_1	D _B	D _{B+1}	D _{B+2}	D _{B+3}
Write Byte 0	L→H				L	H	D0-8 (t_{W+1})			
Write Byte 1	L→H				H	L	D9-17 (t_{W+1})			
Abort Write	L→H				H	H	Don't care			
Write Byte 0		L→H			L	H		D0-8 ($t_{W+1.5}$)		
Write Byte 1		L→H			H	L		D9-17 ($t_{W+1.5}$)		
Write All Bytes		L→H			L	L		D0-17 ($t_{W+1.5}$)		
Abort Write		L→H			H	H		Don't care		
Write Byte 0			L→H		L	H			D0-8 (t_{W+2})	
Write Byte 1			L→H		H	L			D9-17 (t_{W+2})	
Write All Bytes			L→H		L	L			D0-17 (t_{W+2})	
Abort Write			L→H		H	H			Don't care	
Write Byte 0				L→H	L	H				D0-8 ($t_{W+2.5}$)
Write Byte 1				L→H	H	L				D9-17 ($t_{W+2.5}$)
Write All Bytes				L→H	L	L				D0-17 ($t_{W+2.5}$)
Abort Write				L→H	H	H				Don't care

Notes:

1. For all cases, $\overline{R/\overline{W}}$ needs to be active low during the rising edge of K occurring at time t_W
2. For timing definitions refer to the *AC Characteristics* on page 16. Signals must have AC specifications with respect to switching clocks \bar{K} and K.

Absolute Maximum Ratings

Item	Symbol	Rating	Units
Power supply voltage	V_{DD}	-0.5 to 2.6	V
Output power supply voltage	V_{DDQ}	-0.5 to 2.6	V
Input voltage	V_{IN}	-0.5 to 2.6	V
Data out voltage	V_{DOUT}	-0.5 to 2.6	V
Operating temperature	T_A	0 to 70	°C
Junction temperature	T_J	110	°C
Storage temperature	T_{STG}	-55 to +125	°C

Note: Stresses greater than those listed in this table can cause permanent damage to the device. This is a stress rating only and functional operation of the device at these or any other conditions above those indicated in the operational sections of this datasheet is not implied. Exposure to absolute maximum rating conditions for extended periods may affect reliability.

Recommended DC Operating Conditions ($T_A = 0$ to $+70^\circ\text{C}$)

Parameter	Symbol	Minimum	Typical	Maximum	Units	Notes
Supply voltage	V_{DD}	1.8 - 5%		1.8 + 5%	V	1
Output driver supply voltage	V_{DDQ}	1.4		1.9	V	1
Input high voltage	V_{IH}	$V_{REF} + 0.1$		$V_{DDQ} + 0.2$	V	1, 2
Input low voltage	V_{IL}	-0.2		$V_{REF} - 0.1$	V	1, 3
Input reference voltage	V_{REF}	0.68		0.95	V	1, 5
Clocks signal voltage	V_{IN-CLK}	-0.2		$V_{DDQ} + 0.2$	V	1, 4

1. All voltages are referenced to V_{SS} . All V_{DD} , V_{DDQ} , and V_{SS} pins must be connected.
2. $V_{IH}(\text{Max})$ AC = See *Overshoot and Undershoot Timings*.
3. $V_{IL}(\text{Min})$ AC = See *Overshoot and Undershoot Timings*.
4. V_{IN-CLK} specifies the maximum allowable DC excursions of each clock (\overline{K} , \overline{C} , and \overline{C}).
5. Peak-to-peak AC component superimposed on V_{REF} may not exceed 5% of V_{REF} .

Overshoot and Undershoot Timings

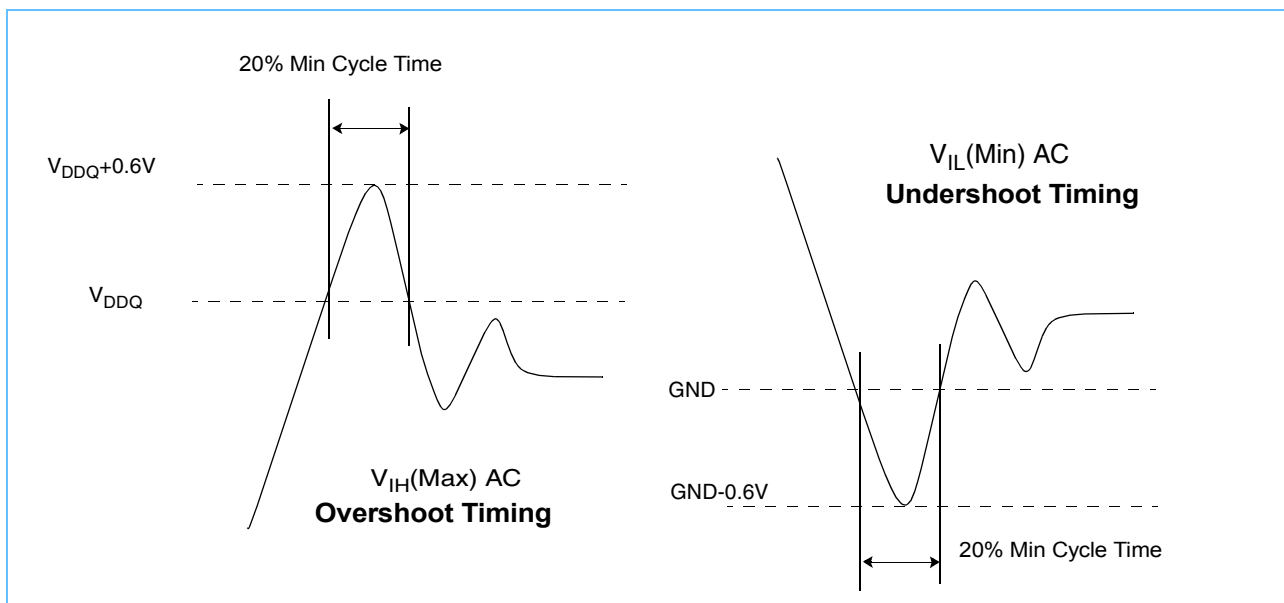

PBGA Thermal Characteristics

Item	Symbol	Rating	Units
Thermal resistance junction to ambient (airflow = 1m/s)	$R_{\theta JA}$	TBD	$^\circ\text{C/W}$
Thermal resistance junction to case	$R_{\theta JC}$	TBD	$^\circ\text{C/W}$
Thermal resistance junction to pins	$R_{\theta JB}$	TBD	$^\circ\text{C/W}$

Capacitance ($T_A = 0$ to $+70^\circ\text{C}$, $V_{DD} = 1.8\text{V} -5\%, +5\%$, $f = 1\text{MHz}$)

Parameter	Symbol	Test Condition	Maximum	Units
Input capacitance	C_{IN}	$V_{IN} = 0\text{V}$	4	pF
Data-in/Out capacitance (DQ0–DQ35)	C_{DQ}	$V_{DIN} = 0\text{V}$	4	pF
Clocks Capacitance (K, \bar{K}, C, \bar{C})	C_{CLK}	$V_{CLK} = 0\text{V}$	4	pF

DC Electrical Characteristics ($T_A = 0$ to $+70^\circ\text{C}$, $V_{DD} = 1.8\text{V} -5\%, +5\%$)

Parameter	Symbol	Minimum	Maximum	Units	Notes
x36 average power supply operating current ($I_{OUT} = 0$, $V_{IN} = V_{IH}$ or V_{IL})	I_{DD30} I_{DD40} I_{DD50}	— — —	600 550 500	mA	1
x18 average power supply operating current ($I_{OUT} = 0$, $V_{IN} = V_{IH}$ or V_{IL})	I_{DD30} I_{DD40} I_{DD50}	— — —	600 550 500	mA	1
Power supply standby current ($R = V_{IH}$, $W = V_{IH}$. All other inputs = V_{IH} or V_{IH} , $I_{IH} = 0$)	I_{SBSS}	—	200	mA	1
Input leakage current, any input (except JTAG) ($V_{IN} = V_{SS}$ or V_{DD})	I_{LI}	-2	+2	uA	
Output leakage current ($V_{OUT} = V_{SS}$ or V_{DDQ} , Q in High-Z)	I_{LO}	-5	+5	uA	
Output "high" level voltage ($I_{OH} = -6\text{mA}$)	V_{OH}	$V_{DDQ}-0.4$	V_{DDQ}	V	2, 3
Output "low" level voltage ($I_{OL} = +6\text{mA}$)	V_{OL}	V_{SS}	$V_{SS}+0.4$	V	2, 3
JTAG leakage current ($V_{IN} = V_{SS}$ or V_{DD})	I_{LIJTAG}	-100	+100	uA	4

1. I_{OUT} = chip output current.
2. Minimum impedance output driver.
3. JEDEC Standard JESD8-6 Class 1 compatible.
4. For JTAG inputs only.
5. Currents are estimates only and need to be verified.

Typical AC Input Characteristics

Item	Symbol	Minimum	Maximum	Notes
AC input logic high	$V_{IH} (ac)$	$V_{REF} + 0.4$		1, 2, 3, 4
AC input logic low	$V_{IL} (ac)$		$V_{REF} - 0.4$	1, 2, 3, 4
Clock input logic high (K, \bar{K}, C, \bar{C})	$V_{IH-CLK} (ac)$	$V_{REF} + 0.4$		1, 2, 3
Clock input logic low (K, \bar{K}, C, \bar{C})	$V_{IL-CLK} (ac)$		$V_{REF} - 0.4$	1, 2, 3

1. The peak-to-peak AC component superimposed on V_{REF} may not exceed 5% of the DC component of V_{REF} .
2. Performance is a function of V_{IH} and V_{IL} levels to clock inputs.
3. See the *AC Input Definition* diagram.
4. See the *AC Input Definition* diagram. The signals should swing monotonically with no steps rail-to-rail with input signals never ringing back past $V_{IH} (AC)$ and $V_{IL} (AC)$ during the input setup and input hold window. $V_{IH} (AC)$ and $V_{IL} (AC)$ are used for timing purposes only.

AC Input Definition

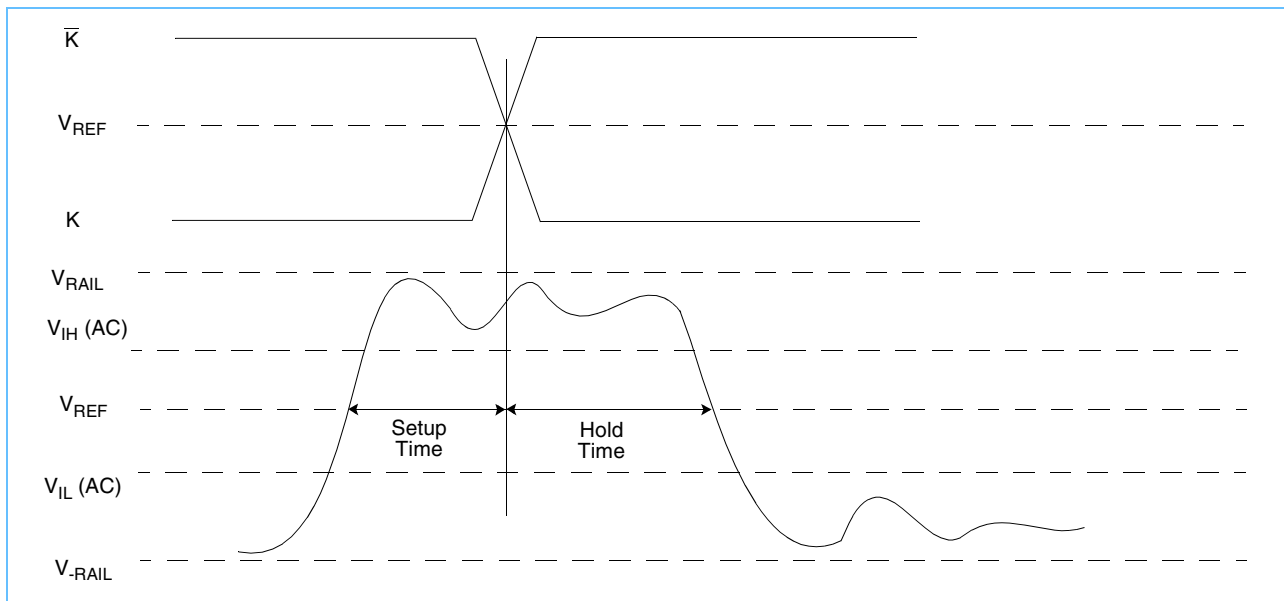

Programmable Impedance Output Driver DC Electrical Characteristics

($T_A = 0$ to $+70^\circ C$, $V_{DD} = 1.8V -5\%, +5\%$, $V_{DDQ} = 1.5, 1.8V$)

Parameter	Symbol	Minimum	Maximum	Units	Notes
Output "high" level voltage	V_{OH}	$V_{DDQ} / 2$	V_{DDQ}	V	1, 3
Output "low" level voltage	V_{OL}	V_{SS}	$V_{DDQ} / 2$	V	2, 3

1. $I_{OH} = \left(\frac{V_{DDQ}}{2}\right) / \left(\frac{RQ}{5}\right) \pm 15\%$ @ $V_{OH} = V_{DDQ} / 2$ For: $175\Omega \leq RQ \leq 350\Omega$
2. $I_{OL} = \left(\frac{V_{DDQ}}{2}\right) / \left(\frac{RQ}{5}\right) \pm 15\%$ @ $V_{OL} = V_{DDQ} / 2$ For: $175\Omega \leq RQ \leq 350\Omega$
3. Parameter tested with $RQ = 250\Omega$ and $V_{DDQ} = 1.5V$.

AC Test Conditions ($T_A = 0$ to $+70^\circ\text{C}$, $V_{DD} = 1.8\text{V} -5\%, +5\%$, $V_{DDQ} = 1.5, 1.8\text{V}$)

Parameter	Symbol	Conditions	Units	Notes
Output driver supply voltage	V_{DDQ}	1.5, 1.8	V	
Input high level	V_{IH}	$V_{REF}+0.5$	V	
Input Low Level	V_{IL}	$V_{REF}-0.5$	V	
Input reference voltage	V_{REF}	0.75, 0.9	V	
Input rise time	T_R	0.35	ns	
Input fall time	T_F	0.35	ns	
Output timing reference level		V_{REF}	V	
Clocks reference level		V_{REF}	V	
Output load conditions				1, 2

1. See *AC Test Loading*.
2. Parameter tested with $R_Q = 250\Omega$ and $V_{DDQ} = 1.5\text{V}$.

AC Test Loading

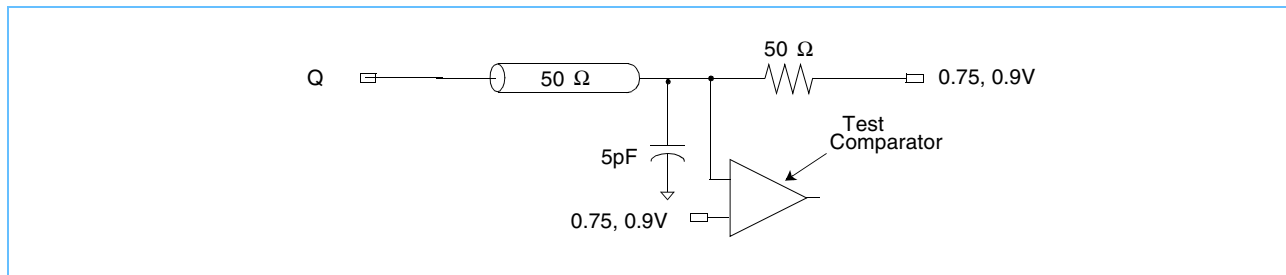

AC Characteristics ($T_A = 0$ to $+70^\circ\text{C}$, $V_{DD} = 1.8\text{V} -5\%, +5\%$)

Parameter	Symbol	30 (333MHz)		Units	Notes
		Min	Max		
Clock					
Cycle time (K, \bar{K} , C, \bar{C})	t_{KHKH}	3.0	3.6	ns	
Clock phase jitter (K, \bar{K} , C, \bar{C})	t_{KC-VAR}		0.12	ns	
Clock high pulse (K, \bar{K} , C, \bar{C})	t_{KHKL}	1.2		ns	
Clock low pulse (K, \bar{K} , C, \bar{C})	t_{KLKH}	1.2		ns	
Clock to $\bar{\text{clock}}$ ($K_H > \bar{K}_H$, $C_H > \bar{C}_H$)	$t_{KH\bar{K}H}$	1.3		ns	
Clock to data clock ($K_H > C_H$, $\bar{K}_H > \bar{C}_H$)	t_{KHCH}	0.0	1.3	ns	
DLL lock (K, C)	$t_{KC-lock}$	1024		cycle	
K static to DLL reset	$t_{KC-reset}$	30		cycle	
Output Times					
C, \bar{C} high to output valid	t_{CHQV}		0.27	ns	1, 3
C, \bar{C} high to output hold	t_{CHQX}	-0.27		ns	1, 3
C, \bar{C} high to echo clock valid	t_{CHCQV}		0.25	ns	3
C, \bar{C} high to echo clock hold	t_{CHCQX}	-0.25		ns	3
CQ, $\bar{C}\bar{Q}$ high to output valid	t_{CQHQV}		0.27	ns	1, 3
CQ, $\bar{C}\bar{Q}$ high to output hold	t_{CQHQX}	-0.27		ns	1, 3
C high to output high-Z	t_{CHQZ}		0.27	ns	1, 3
C high to output low-Z	t_{CHQX1}	-0.27		ns	1, 3
Setup Times					
Address valid to K, \bar{K} rising edge	t_{AVKH}	0.33	—	ns	2
Control inputs valid to K rising edge	t_{IVKH}	0.33	—	ns	2
Data-in valid to K, \bar{K} rising edge	t_{DVKH}	0.30	—	ns	2
Hold Times					
K rising edge to address hold	t_{KHAX}	0.33	—	ns	2
K rising edge to control inputs hold	t_{KHIX}	0.33	—	ns	2
K, \bar{K} rising edge to data-in hold	t_{KHDX}	0.30	—	ns	2

1. See *AC Test Loading* on page 15.
2. During normal operation, V_{IH} , V_{IL} , T_{RISE} , and T_{FALL} of inputs must be within 20% of V_{IH} , V_{IL} , T_{RISE} , and T_{FALL} of clock.
3. If C, \bar{C} are tied high, then K, \bar{K} become the references for C, \bar{C} timing parameters.

AC Characteristics ($T_A = 0$ to $+70^\circ\text{C}$, $V_{DD} = 1.8\text{V} -5\%, +5\%$)

Parameter	Symbol	40 (250MHz)		50 (200MHz)		Units	Notes
		Min	Max	Min	Max		
Clock							
Cycle time (K, \bar{K} , C, \bar{C})	t_{KHKH}	4.0	5.85	5.0	6.3	ns	
Clock phase jitter (K, \bar{K} , C, \bar{C})	t_{KC-VAR}		0.2		0.2	ns	
Clock high pulse (K, \bar{K} , C, \bar{C})	t_{KHKL}	1.6		2.0		ns	
Clock low pulse (K, \bar{K} , C, \bar{C})	t_{KLKH}	1.6		2.0		ns	
Clock to clock ($K_H > \bar{K}_H$, $C_H > \bar{C}_H$)	$t_{KH\bar{K}H}$	1.8		2.2		ns	
Clock to data clock ($K_H > C_H$, $\bar{K}_H > \bar{C}_H$)	t_{KHCH}	0.0	1.8	0.0	2.3	ns	
DLL lock (K, C)	$t_{KC-lock}$	1024		1024		cycle	
K static to DLL reset	$t_{KC-reset}$	30		30		cycle	
Output Times							
C, \bar{C} high to output valid	t_{CHQV}		0.35		0.38	ns	1, 3
C, \bar{C} high to output hold	t_{CHQX}	-0.35		-0.38		ns	1, 3
C, \bar{C} high to echo clock valid	t_{CHCQV}		0.33		0.36	ns	3
C, \bar{C} high to echo clock hold	t_{CHCQX}	-0.33		-0.36		ns	3
CQ, $\bar{C}\bar{Q}$ High to output valid	t_{CQHQV}		0.35		0.36	ns	1, 3
CQ, $\bar{C}\bar{Q}$ high to output hold	t_{CQHQX}	-0.35		-0.36		ns	1, 3
C High to output high-Z	t_{CHQZ}		0.35		0.38	ns	1, 3
C High to output low-Z	t_{CHQX1}	-0.35		-0.38		ns	1, 3
Setup Times							
Address valid to K, \bar{K} rising edge	t_{AVKH}	0.4	—	0.5	—	ns	2
Control inputs valid to K rising edge	t_{IVKH}	0.4	—	0.5	—	ns	2
Data-in valid to K, \bar{K} rising edge	t_{DVKH}	0.35	—	0.4	—	ns	2
Hold Times							
K rising edge to address hold	t_{KHAX}	0.4	—	0.5	—	ns	2
K rising edge to Control Inputs Hold	t_{KHIX}	0.4	—	0.5	—	ns	2
K, \bar{K} rising edge to data-in hold	t_{KHDX}	0.35	—	0.4	—	ns	2

1. See *AC Test Loading* on page 15.
2. During normal operation, V_{IH} , V_{IL} , T_{RISE} , and T_{FALL} of inputs must be within 20% of V_{IH} , V_{IL} , T_{RISE} , and T_{FALL} of clock.
3. If C, \bar{C} are tied high, then K, \bar{K} become the references for C, \bar{C} timing parameters.

IEEE 1149.1 TAP and Boundary Scan

The SRAM provides a limited set of JTAG functions to test the interconnection between SRAM I/Os and printed circuit board traces or other components. There is no multiplexer in the path from I/O pins to the RAM core.

In conformance with IEEE Standard 1149.1, the SRAM contains a TAP controller, instruction register, boundary scan register, bypass register, and ID register.

The TAP controller has a standard 16-state machine that resets internally on power-up. Therefore, a TRST signal is not required.

Signal List

- TCK: test clock
- TMS: test mode select
- TDI: test data-in
- TDO: test data-out

JTAG DC Operating Characteristics ($T_A = 0$ to $+70^\circ\text{C}$)

Operates with JEDEC Standard 8-5 (1.8V) logic signal levels

Parameter	Symbol	Minimum	Typical	Maximum	Units	Notes
JTAG input high voltage	V_{IH1}	1.3	—	$V_{DD}+0.3$	V	1
JTAG input low voltage	V_{IL1}	-0.3	—	0.5	V	1
JTAG output high level	V_{OH1}	$V_{DD}-0.4$	—	V_{DD}	V	1, 2
JTAG output low level	V_{OL1}	V_{SS}	—	0.4	V	1, 3

1. All JTAG inputs and outputs are LVTTTL-compatible.
 2. $I_{OH1} \geq -12\text{mA}$
 3. $I_{OL1} \geq +12\text{mA}$.

JTAG AC Test Conditions ($T_A = 0$ to $+70^\circ\text{C}$, $V_{DD} = 1.8\text{V} -5\%, +5\%$)

Parameter	Symbol	Conditions	Units
Input pulse high level	V_{IH1}	1.3	V
Input pulse low level	V_{IL1}	0.5	V
Input rise time	T_{R1}	1.0	ns
Input fall time	T_{F1}	1.0	ns
Input and output timing reference level		0.9	V

JTAG AC Characteristics ($T_A = 0$ to $+70^\circ\text{C}$, $V_{DD} = 1.8\text{V} -5\%, +5\%$)

Parameter	Symbol	Minimum	Maximum	Units	Notes
TCK cycle time	t_{THTH}	20	—	ns	
TCK high pulse width	t_{THTL}	7	—	ns	
TCK low pulse width	t_{TLTH}	7	—	ns	
TMS setup	t_{MVTH}	4	—	ns	
TMS hold	t_{THMX}	4	—	ns	
TDI setup	t_{DVTH}	4	—	ns	
TDI hold	t_{THDX}	4	—	ns	
TCK low to valid data	t_{TLOV}	—	7	ns	1

1. See AC Test Loading on page 15.

JTAG Timing Diagram

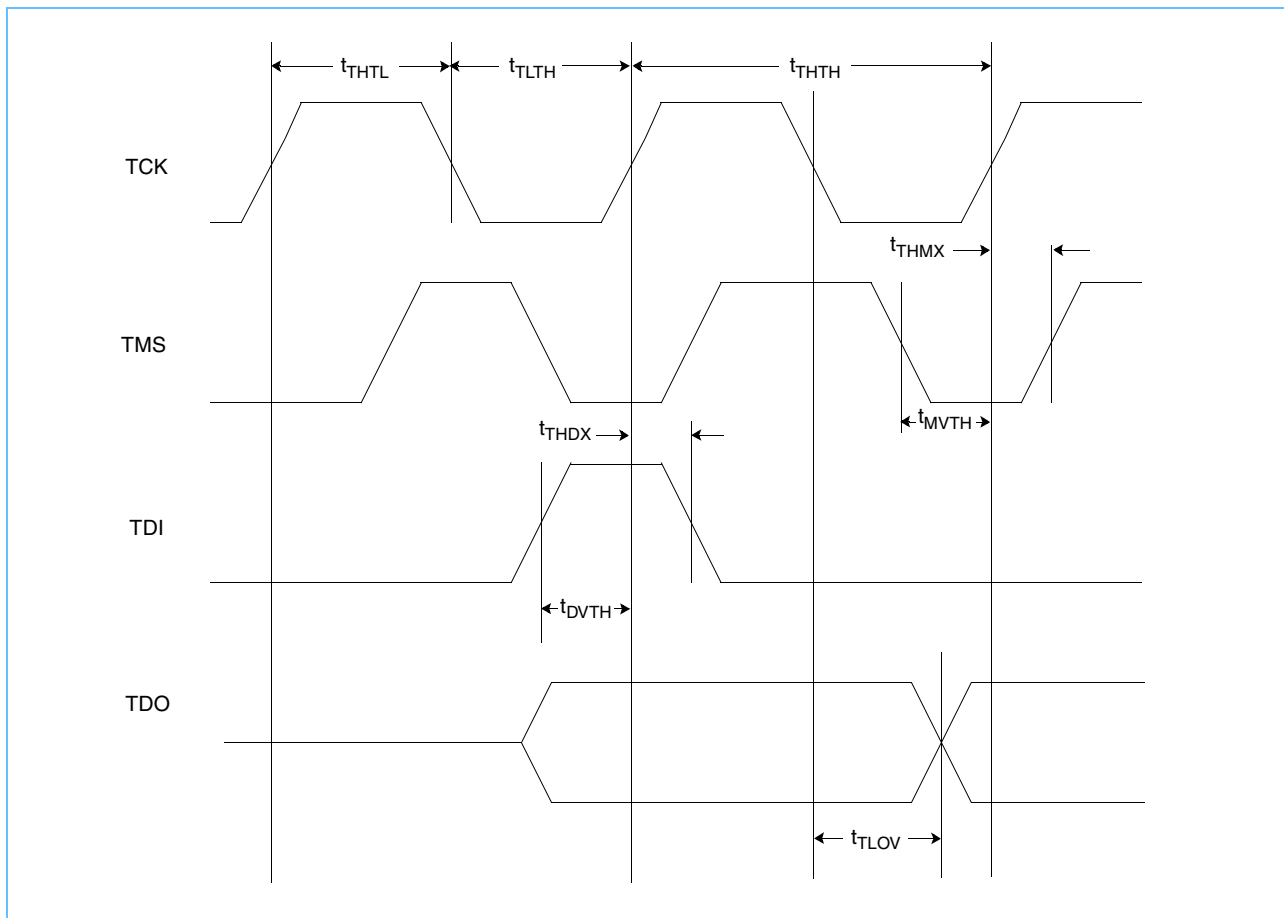

Scan Register Definition

Register Name	Bit Size x18 or x36
Instruction	3
Bypass	1
ID	32
Boundary Scan	109

ID Register Definition

Part	Field Bit Number and Description			
	Revision Number (31:29)	Part Configuration (28:12)	JEDEC Code (11:1)	Start Bit (0)
2M x 18	000	00def0wx0t0q0b0s0	000 101 001 00	1
1M x 36	000	00def0wx0t0q0b0s0	000 101 001 00	1

Part Configuration Definition:

def = 010 for 36Mb
 wx = 11 for x36, 10 for x18
 t = 1 for DLL, 0 for non-DLL
 q = 1 for QUADB4, 0 for DDR-II
 b = 1 for burst of 4, 0 for burst of 2
 s = 1 for separate I/O, 0 for common I/O

Instruction Set

Code	Instruction	TDO Output	Notes
000	EXTEST	Boundary Scan Register	2,6
001	IDCODE	32-bit Identification Register	
010	SAMPLE-Z	Boundary Scan Register	1, 2
011	PRIVATE	Do not use	5
100	SAMPLE	Boundary Scan Register	4
101	PRIVATE	Do not use	5
110	PRIVATE	Do not use	5
111	BYPASS	Bypass Register	3

1. Places Qs in high-Z in order to sample all input data, regardless of other SRAM inputs.
2. TDI is sampled as an input to the first ID register to allow for the serial shift of the external TDI data.
3. BYPASS register is initiated to V_{SS} when BYPASS instruction is invoked. The BYPASS register also holds the last serially loaded TDI when exiting the shift-DR state.
4. SAMPLE instruction does not place DQs in high-Z.
5. This instruction is reserved. Invoking this instruction will cause improper SRAM functionality.
6. This EXTEST is not IEEE 1149.1-compliant. By default, it places Q in high-Z. If the internal register on the scan chain is set high, Q will be updated with information loaded via a previous SAMPLE instruction. The actual transfer occurs during the update IR state after EXTEST is loaded. The value of the internal register can be changed during SAMPLE and EXTEST only.

List of IEEE 1149.1 Standard Violations

- 7.2.1.b, e
- 7.7.1.a-f
- 10.1.1.b, e
- 10.7.1.a-d
- 6.1.1.d

JTAG Block Diagram

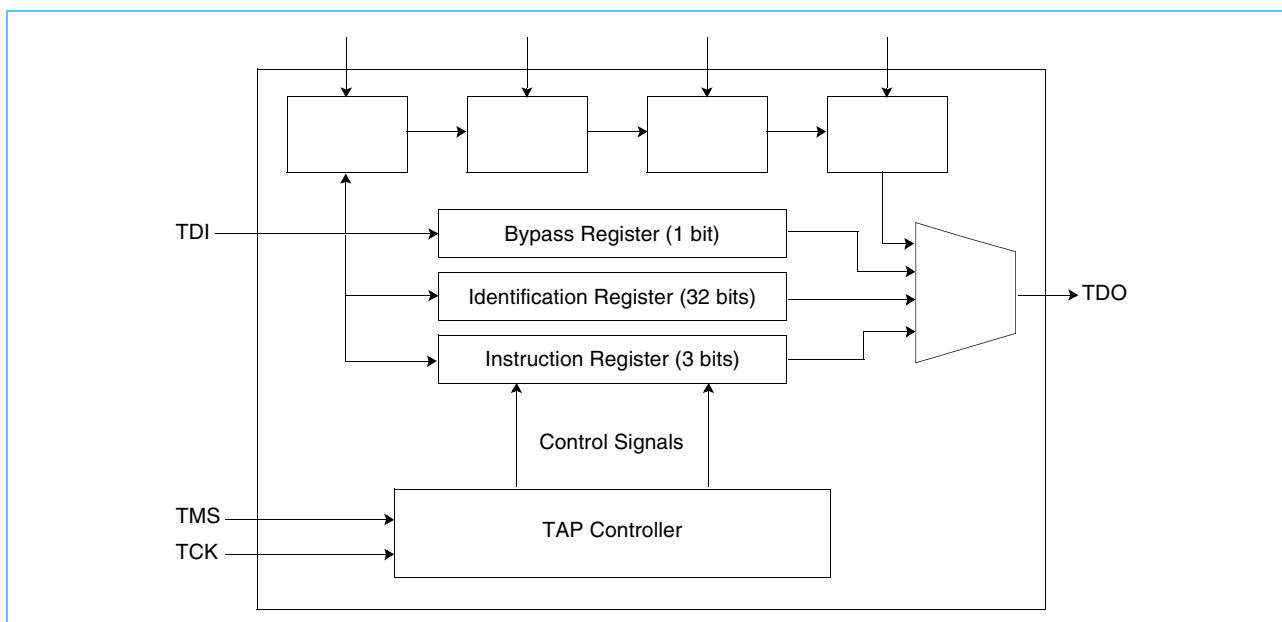

TAP Controller State Machine

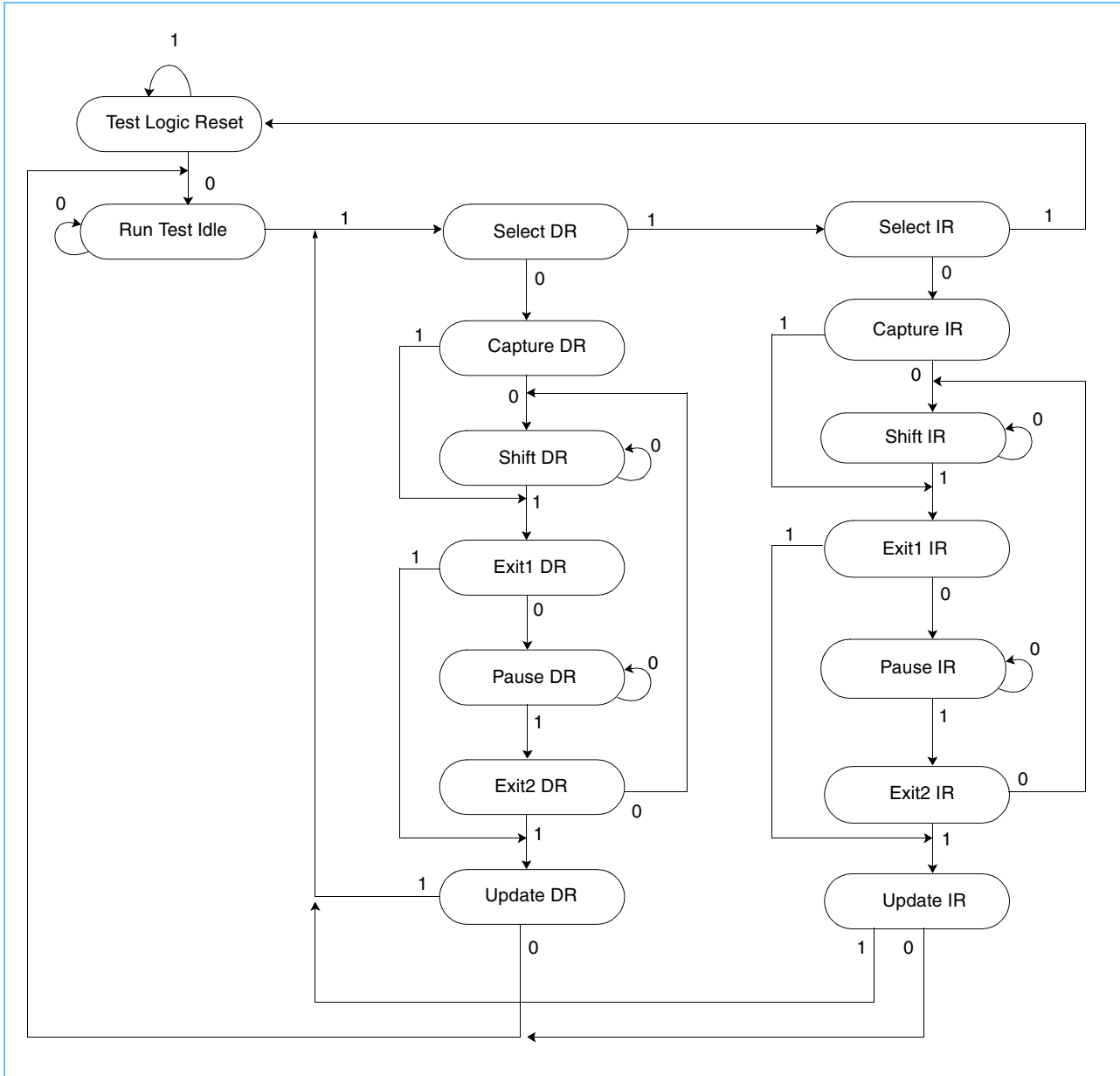



Boundary Scan Exit Order The same length is used for x18 and x36 I/O configuration.

Order	Pin ID
1	6R
2	6P
3	6N
4	7P
5	7N
6	7R
7	8R
8	8P
9	9R
10	11P
11	10P
12	10N
13	9P
14	10M
15	11N
16	9M
17	9N
18	11L
19	11M
20	9L
21	10L
22	11K
23	10K
24	9J
25	9K
26	10J
27	11J
28	11H
29	10G
30	9G
31	11F
32	11G
33	9F
34	10F
35	11E
36	10E

Order	Pin ID
37	10D
37	9E
39	10C
40	11D
41	9C
42	9D
43	11B
44	11C
45	9B
46	10B
47	11A
48	10A
49	9A
50	8B
51	7C
52	6C
53	8A
54	7A
55	7B
56	6B
57	6A
58	5B
59	5A
60	4A
61	5C
62	4B
63	3A
64	2A
65	1A
66	2B
67	3B
68	1C
69	1B
70	3D
71	3C
72	1D

Order	Pin ID
73	2C
74	3E
75	2D
76	2E
77	1E
78	2F
79	3F
80	1G
81	1F
82	3G
83	2G
84	1H
85	1J
86	2J
87	3K
88	3J
89	2K
90	1K
91	2L
92	3L
93	1M
94	1L
95	3N
96	3M
97	1N
98	2M
99	3P
100	2N
101	2P
102	1P
103	3R
104	4R
105	4P
106	5P
107	5N
108	5R
109	Internal

1) NC pins as defined on *FBGA pinouts* on page 2 are read as “don’t cares”.
 2) State of Internal pin (#109) is loaded via JTAG.

11 x 15 FBGA Dimensions

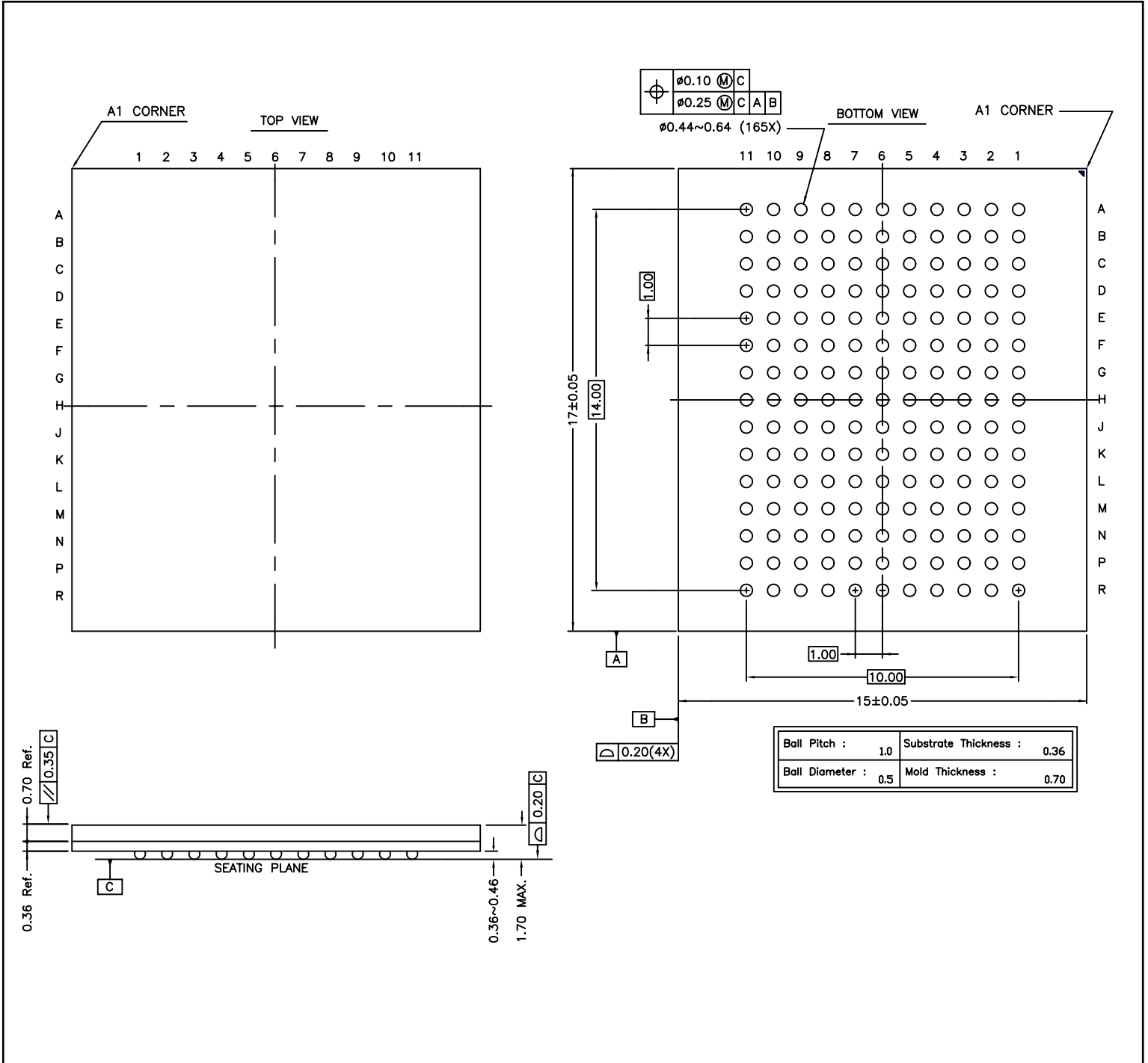



ORDERING INFORMATION

Commercial Range: 0°C to +70°C

Speed	Order Part No.	Organization	Package
250 MHz	IS61DDB41M36-250M3	1Mx36	165 BGA
	IS61DDB42M18-250M3	2Mx18	165 BGA
	IS61DDB42M18-250M3L	2Mx18	165 BGA, Lead-free