

PACKAGING INFORMATION

330-mil Plastic SOP Package Code: U (28-pin)

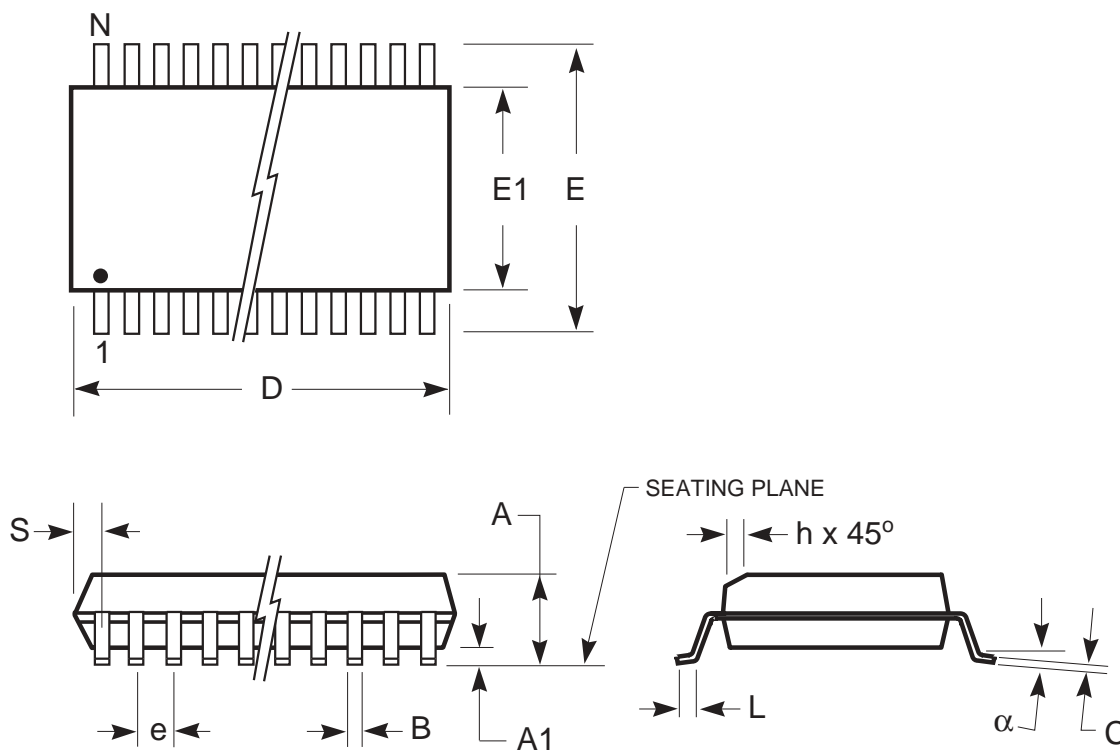

| | MILLIMETERS | | INCHES | |
|-----------|-------------|-------|-----------|-------|
| Sym. | Min. | Max. | Min. | Max. |
| No. Leads | 28 | | 28 | |
| A | — | 2.84 | — | 0.112 |
| A1 | 0.10 | — | 0.004 | — |
| B | 0.36 | 0.51 | 0.014 | 0.020 |
| C | 0.25 | — | 0.010 | — |
| D | 17.98 | 18.24 | 0.708 | 0.718 |
| E | 11.51 | 12.12 | 0.453 | 0.477 |
| E1 | 8.28 | 8.53 | 0.326 | 0.336 |
| e | 1.27 BSC | | 0.050 BSC | |
| h | 0.30 | 0.51 | 0.012 | 0.020 |
| L | 0.71 | 1.14 | 0.028 | 0.045 |
| α | 0° | 8° | 0° | 8° |
| S | 0.58 | 1.19 | 0.023 | 0.047 |

Notes:

1. Controlling dimension: inches, unless otherwise specified.
2. BSC = Basic lead spacing between centers.
3. Dimensions D and E1 do not include mold flash protrusions and should be measured from the bottom of the package.
4. Formed leads shall be planar with respect to one another within 0.004 inches at the seating plane.

Copyright © 2003 Integrated Silicon Solution, Inc. All rights reserved. ISSI reserves the right to make changes to this specification and its products at any time without notice. ISSI assumes no liability arising out of the application or use of any information, products or services described herein. Customers are advised to obtain the latest version of this device specification before relying on any published information and before placing orders for products.